

LUBRICATION EQUIPMENT . MADE IN GERMANY

UMETA



We make it move.



If you ever see a grease nipple anywhere, it's most probably one of ours. After all, since 1926 UMETA has been the address for high-quality manual grease technology, which, unlike many other companies, we are still producing in Germany. And we plan to carry on doing so.

Our manufacturing plant is in Bielefeld

because we owe everything to this region and to the people who live here!

This is where we at UMETA live and work. This is where we create quality, with expertise, experience, and highly up-to-date production plants. It's no coincidence that grease nipples and grease guns from UMETA are known throughout the world for their durability and functional safety. One of our special strengths is our enormous flexibility when it comes to customer wishes. If someone needs a custom-made solution for his special design requirements, then he gets it - without any ifs or buts. We place a high priority on first-class advice and customer care. This is why we were the first company in the industry to not only be certified by TÜV in accordance with DIN ISO 9001:2000 but also for "customer satisfaction and quality of service". As a modern, family-run company with tradition, we aim to represent dependability and reliability and remain a trustworthy partner well into the future.



Why not check us out yourself!

Yours

A handwritten signature in black ink, appearing to read "Frank Heuer". The signature is written in a cursive, flowing style.



FÖRDERVEREIN

GOOD HOPE CENTRE E.V.



UMETA ACCEPTS RESPONSIBILITY!

We are fortunate enough to be able to live in an affluent society, but we also have an obligation to help people who do not share this luck.

UMETA supports social institutions in Germany, for example the Children's Cancer Clinic in Bielefeld, sports clubs, charitable organisations etc. Since 2007, UMETA has also given considerable commitment to Tanzania, one of the 10 poorest countries in the world.

For us at UMETA it is intolerable that one side of the world has plenty, and that on the other side of the world abandoned orphans are starving or dying of AIDS. Anyone who has personally experienced this will never be able to banish the images as long as they live. To fight this appalling situation, we founded the Good Hope Centre funding association in September 2007 together with some good friends.

Since then, our work at the foot of Mount Kilimanjaro has been producing a home for orphans as well as a primary school. This Happy Watoto Homes & Schools in Ngorika provides "our" 120 orphans, in addition to 160 needy children from the local area, optimum future prospects through a protected childhood and good education.

This "village" has been opened since May 2011.

We are receiving considerable support from various directions such as business partners, personal friends, visitors to our funding events, well-known people or politicians. Despite this, we need to be able to permanently safeguard the operating costs for our home. I therefore ask you:

Please help us! "Our children in Tanzania" depend on your help!



WWW.GOOD-HOPE-CENTRE.DE



Please visit our homepage www.good-hope-centre.de and inform yourself about the various ways you can help us. Why don't you join our funding association?

Unfortunately we can't save the whole world, but everyone here at UMETA is doing their very best to do what is possible within our means. Please help us to achieve this!

I would like to thank you wholeheartedly in the name of "our children" and all the committed staff at UMETA for your help!

Best regards,

Frank Maser



PETER MAFFAY



"I REALLY WOULD LIKE TO PRAISE THE GOOD HOPE CENTRE FUNDRAISING ASSOCIATION FOR ITS EXCELLENT WORK! I WILL SUPPORT YOU HOWEVER I CAN!"

ULI STEIN



"IT IS A REAL ACHIEVEMENT TO SUPPORT SUCH A FANTASTIC ACTION NOT JUST PASSIVELY, BUT TO ACTIVELY PARTICIPATE AS WELL. I REALLY HOPE WE WILL BE ABLE TO ACHIEVE A LOT WITH OUR ASSOCIATION"

UDO LINDENBERG



"I AM EXTREMELY PLEASED THAT I CAN SUPPORT YOUR WORK WITH THE "UDO LINDENBERG FOUNDATION". KEEP UP THE GOOD WORK! AHOI, UDO"

WERNER SCHULZE-ERDEL



"IT IS REALLY NICE TO BE ABLE TO WORK WITH YOU. I'M REALLY LOOKING FORWARD TO THE MANY FUTURE ACTIONS AND EVENTS WHERE I CAN HELP YOU."

ALFONS SCHUHBECK



"THERE REALLY SHOULDN'T BE ANY CHILDREN IN NEED! THAT IS WHY I AM REALLY PLEASED TO HELP."

AXEL SCHULZ



"NO MATTER HOW, YOUR CHILDREN IN TANZANIA CAN ALWAYS COUNT ON ME!"

■ UMETA PRODUCTS

Quality – safety – flexibility **UMETA keeps your machines moving**

For more than 80 years, UMETA lubrication products have been guaranteeing reliable maintenance and upkeep of high-quality machines and equipment. Even nowadays, breakdowns caused by non-lubricated or incorrectly lubricated equipment can cost millions.

To keep your equipment permanently moving, we can offer the largest range of lubricating nipples available the whole world over in addition to grease guns and accessories for all application areas. We know exactly how important good tools are for effective work, and would be pleased to advise you at any time. Our aim is to find an optimum solution for every lubrication problem, whether direct by using our huge standard range, or even using products which we develop together with your company.

Speed counts! This is why a large part of our program is permanently available to you from stock.

We produce our high-quality lubrication technology exclusively in Germany. The established UMETA quality is guaranteed here by highly-modern production facilities, certified quality management and innovative product management.

Turned parts to customer specifications are now playing an increasing part within our company. In this case, we can fall back on decades of experience and the knowledge gained from lubricating technology. Our customers value the flexibility and reliability of our automatic devices and CNC lathes. Combination of this department with the assembly sector allows us to process complex components and to produce in variable dimensions, materials and batch sizes.



GREASE GUNS	6		
UMETA TWIN-LOCK® SYSTEM	7		
UMETA EVER-FLOW-SYSTEM	7		
UMETA GREASE GUN KITS	7		
HAND LEVER GREASE GUNS	8		
ONE-HAND GREASE GUNS	13		
AIR-OPERATED GREASE GUNS	14		
PUSH-TYPE AND SCREW-TYPE GREASE GUNS	15		
OIL GUNS	18		
ACCESSORIES FOR GREASE GUNS	19		
NOZZLE TUBES	20		
NOZZLE AND HYDRAULIC COUPLERS	21		
OIL-PROOF HYDRAULIC COUPLERS	22		
HIGH PRESSURE HOSES	23		
QUICK-ADAPTERS	24		
WALL BRACKETS	25		
GREASE CARTRIDGES	25		
GARAGE EQUIPMENT	26		
SUCTION GUNS	27		
ACCESSORIES FOR SUCTION GUNS	29		
OTHER GARAGE EQUIPMENT	30		
INJECTION GUNS	34		
GREASE NIPPLES TO DIN	36		
HYDRAULIC-TYPE GREASE NIPPLES	37		
... WITH SELF-FORMING THREAD	44		
... DRIVE-IN VERSION	46		
... SPECIAL DESIGNS	48		
BALL-TYPE GREASE NIPPLES	50		
... DRIVE-IN VERSIONS	52		
FLUSH-TYPE GREASE NIPPLES	54		
... WITH SELF-FORMING THREAD	56		
... DRIVE-IN VERSIONS	57		
... SPECIAL DESIGNS	59		
BUTTON-HEAD GREASE NIPPLES	60		
... SPECIAL DESIGNS	66		
BAJONET GREASE NIPPLES	68		
GREASE NIPPLES ASSORTMENTS	69		
ACCESSORIES FOR GREASE NIPPLES	70		
GREASE NIPPLES TO SAE-J534	71		
HYDRAULIC-TYPE GREASE NIPPLES	71		
... WITH SELF-FORMING THREAD	73		
... DRIVE-IN VERSION	74		
... RIVET FITTINGS	75		
FLUSH-TYPE GREASE NIPPLES	75		
BUTTON-HEAD GREASE NIPPLES	76		
... WITH CHECK VALVE	77		
ADAPTERS/ELBOW BODIES	77		
GREASE NIPPLES ASSORTMENTS	77		
LOCKING PLUGS	78		
... WITH SELF-FORMING THREAD	78		
INTERNATIONAL TYPE CHART	78		
TURNED PARTS	79		
EXAMPLES OF MACHINING FACILITIES	79		
AIR BLEED VALVES	80		
LOCKING PLUGS	81		
IMPORTANT INFORMATION	82		
UMETA-HISTORY	82		
SAFETY INFORMATION	82		
GENERAL INFORMATION	82		
UMETA REFERENCE INDEX	83		



* Subject to our guarantee terms and conditions which can be found at www.umeta.com

GREASE GUNS

UMETA grease guns stand for highest quality and reliability.

We are certain of the quality of UMETA products and have a guaranty of four years for all UMETA TWIN-LOCK® grease guns with respect to function. Accurate manufacturing, high quality materials and intelligent product features turn our guns into effective precision tools that effortlessly reach high lubricating pressures.

UMETA TWIN-LOCK® grease guns will be delivered with a user's manual, either in a polybag, or in a coloured cardboard box.

All UMETA TWIN-LOCK® grease guns for 400g (14.0 oz.) grease cartridges comply with DIN 1283 as regards physical dimensions and performance and are suitable for grease cartridges according to DIN 1284.



Our grease guns 75/PK und 75/PL are DLG-certified



Of course, our quality management is ISO 9001-2008-certified

UMETA GREASE GUNS – ADVANTAGES AT A GLANCE

- UMETA TWIN-LOCK® system
- rolled coarse thread for high stability and easy disassembly
- special pressure stability by cast aluminium head and thick-walled barrel
- easy insertion of the plunger into the cartridge by a bulge in the barrel
- inner cartridge stopper
- stable hand lever with security handle
- ergonomic T-grip with jam protection
- knurled barrel for better hold and grip
- separate air release valve or filler valve
- special constructions available
- colours and imprints as per customer's request
- individual packaging
- high wearing security
- even after 30,000 strokes no wear is detectable
- available according to DIN 1283
- wide range of accessories

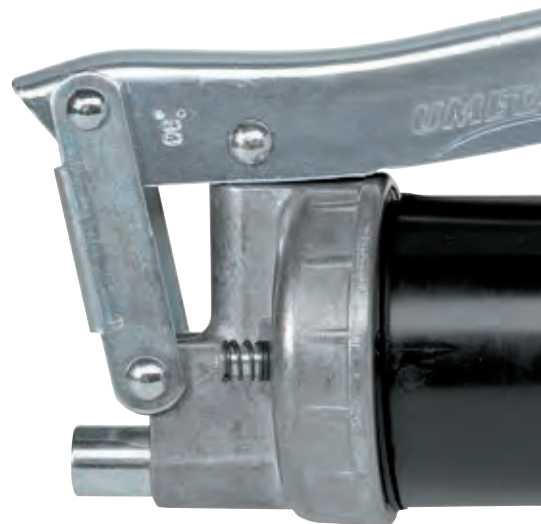

■ UMETA TWIN-LOCK®-SYSTEM – THE LIFE INSURANCE FOR YOUR MACHINES AND EQUIPMENT

When maintaining your high quality machines and equipment, you should absolutely avoid quasi-lubrication!

What does quasi-lubrication mean?

Upon continuous operation, abrasion can easily take place between the metal piston and the metal cylinder of the grease gun. For this reason, the grease at the top of the piston can be pressed back into the cartridge at a low operating pressure without being noticed. In spite of all efforts, no grease will be transported to the lubrication spot. In order not to expose your machines to this risk, we developed the UMETA TWIN-LOCK® system. In connection with two special sealing elements, it protects the precision piston from wear upon continuous operation. By the special arrangement of the sealing elements, the UMETA TWIN-LOCK® system avoids quasi-

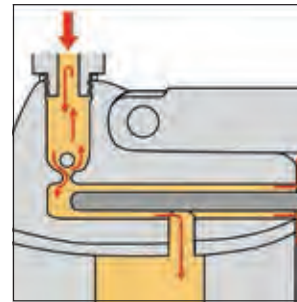

without UMETA TWIN-LOCK® System

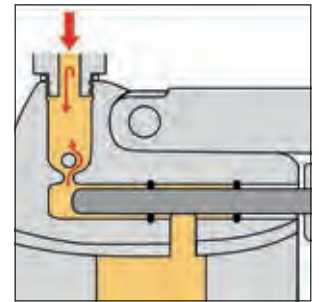

with UMETA TWIN-LOCK® System

lubrication and grease escaping the piston. The sealing elements are designed in a way that they adjust themselves to the corresponding operating pressure with respect to their sealing effect. For this unique advantage UMETA grease guns are worldwide renowned.

■ UMETA EVER-FLOW SYSTEM

The EVER-FLOW system invented by UMETA ensures perfect functioning of the UMETA TWIN-LOCK® gun, even with thick grease and at the lowest temperatures. This is ensured by an outlet valve equipped with a special ball stopper. Even semifluid biological grease will easily be transported by the vacuum developing during the pumping process. This is another advantage of UMETA's, where many other competitors' products fail.

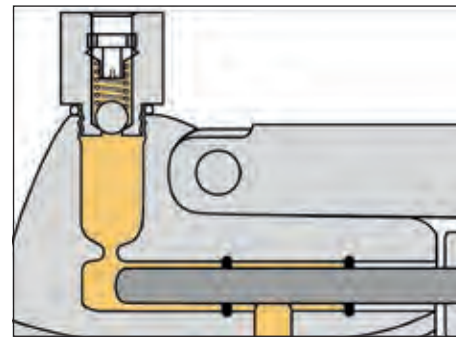

■ UMETA GREASE GUN KITS

The well-established UMETA accessories for grease guns offer you the optimal solution for any application. We assembled the most common grease gun kits, which consist of the UMETA grease gun of your choice and the following standard accessory parts.

► Our most common standard kits:



110/G – nozzle tube with hydraulic coupling



340/GLN – hose 300 mm (12") with hydraulic coupling



Grease gun equipped with standard air release valve



Grease gun equipped with standard filler valve



Grease gun equipped with standard filler valve and nozzle tube

HAND LEVER GREASE GUNS

75/PK Silver



barrel version	silver painted steel barrel – DIN 1283 special colours available Ø 56 mm (2.2")
barrel length	296 mm (11.6")
suitable for	grease up to NLGI 3
filling capacity	400 g (14.0 oz.) grease cartridge / 500 ccm (16.0 oz.) bulk grease
connection thread	M 10 x 1 oder G 1/8 upon request 1/8 NPT

Connection	Packed in	Scope of delivery	Ref. No.:
M 10 x 1	polybag	without accessories	V000286
M 10 x 1	polybag	with 340/GLN	V000281
M 10 x 1	polybag	with 110/G	V000333
M 10 x 1	polybag	with 110/G + 340/GLN	V000524
M 10 x 1	polybag	with filler valve	V000342
M 10 x 1	cardboard box	without accessories	V000306
M 10 x 1	cardboard box	with 340/GLN	V000308
M 10 x 1	cardboard box	with 110/G	V000378
M 10 x 1	cardboard box	with 110/G + 340/GLN	V000717
M 10 x 1	cardboard box	with filler valve	V000319

* special version USA

75/PK Zinc



barrel version	made of zinc-plated steel – DIN 1283 special colours available Ø 56 mm (2.2")
barrel length	296 mm (11.6")
suitable for	grease up to NLGI 3
filling capacity	400 g (14.0 oz.) grease cartridge / 500 ccm (16.0 oz.) bulk grease
connection thread	M 10 x 1 or G 1/8 upon request 1/8 NPT

Connection	Packed in	Scope of delivery	Ref. No.:
M 10 x 1	polybag	without accessories	V000301
M 10 x 1	polybag	with 340/GLN	V000309
M 10 x 1	polybag	with 110/G	V000860
M 10 x 1	polybag	with 110/G + 340/GLN	V001167
M 10 x 1	polybag	with filler valve	V000432
M 10 x 1	cardboard box	without accessories	V000310
M 10 x 1	cardboard box	with 340/GLN	V000573
M 10 x 1	cardboard box	with 110/G	V000567
M 10 x 1	cardboard box	with 110/G + 340/GLN	V001166
M 10 x 1	cardboard box	with filler valve	V000358

Hand Lever Grease Gun with high quality silver painted steel barrel

- for 400 g (14.0 oz.) grease cartridges or 500 ccm (16.0 oz.) bulk grease
- with UMETA TWIN-LOCK® system and EVER-FLOW system
- standard air release valve, alternatively with filler valve according to DIN 1283

operating pressure	400 bar / 5,800 PSI
output	approx. 1.9 ccm (0.06 oz.)/stroke
testing pressure	800 bar / 11,600 PSI
gun dimension	400 x 128 x 60 mm (15.7 x 5.0 x 2.36")
packed in	printed UMETA polybag or printed UMETA cardboard box
weight	net 1,250 g (44.1 oz.) + accessories and packaging

Connection	Packed in	Scope of delivery	Ref. No.:
G 1/8	polybag	without accessories	V000287
G 1/8	polybag	with 340/GLN	V000276
G 1/8	polybag	with 110/G	V000456
G 1/8	polybag	with 110/G + 340/GLN	V001174
G 1/8	polybag	with filler valve	V001045
G 1/8	cardboard box	without accessories	V000402
G 1/8	cardboard box	with 340/GLN	V000449
G 1/8	cardboard box	with 110/G	V000535
G 1/8	cardboard box	with 110/G + 340/GLN	V001176
G 1/8	cardboard box	with filler valve	V000495
1/8 NPT	polybag	with 95/G	V000667
1/8 NPT	polybag	with filler valve* and 95/G	V000616
1/8 NPT	cardboard box	with filler valve* and 95/G	V000403

Hand Lever Grease Gun with high quality zinc-plated steel barrel

- for 400 g (14.0 oz.) grease cartridges or 500 ccm (16.0 oz.) bulk grease
- with UMETA TWIN-LOCK® system and EVER-FLOW-System
- standard air release valve, alternatively with filler valve according to DIN 1283

operating pressure	400 bar / 5,800 PSI
output	approx. 1.9 ccm (0.06 oz.)/stroke
testing pressure	800 bar / 11,600 PSI
gun dimension	400 x 128 x 60 mm (15.7 x 5.0 x 2.36")
packed in	printed UMETA polybag or printed UMETA cardboard box
weight	net 1,250 g (44.1 oz.) + accessories and packaging

Connection	Packed in	Scope of delivery	Ref. No.:
G 1/8	polybag	without accessories	V000349
G 1/8	polybag	with 340/GLN	V001408
G 1/8	polybag	with 110/G	V001182
G 1/8	polybag	with 110/G + 340/GLN	V001181
G 1/8	polybag	with filler valve	V001249
G 1/8	cardboard box	without accessories	V001172
G 1/8	cardboard box	with 340/GLN	V001409
G 1/8	cardboard box	with 110/G	V001185
G 1/8	cardboard box	with 110/G + 340/GLN	V001184
G 1/8	cardboard box	with filler valve	V001250

75/PL Zinc

barrel version	made of zinc-plated steel Ø 56 mm (2.2")
barrel length	370 mm (14.6")
suitable for	grease up to NLGI 3
filling capacity	500 g (17.5 oz.) grease cartridge/600 ccm (20 oz.) bulk grease
connection thread	M 10 x 1 or G 1/8 upon request 1/8 NPT

Connection	Packed in	Scope of delivery	Ref. No.:
M 10 x 1	polybag	without accessories	V000662
M 10 x 1	polybag	with 340/GLN	V000810
M 10 x 1	polybag	with 110/G	V000803
M 10 x 1	polybag	with 110/G + 340/GLN	V001199
M 10 x 1	polybag	with filler valve	V001197
M 10 x 1	cardboard box	without accessories	V000439
M 10 x 1	cardboard box	with 340/GLN	V001422
M 10 x 1	cardboard box	with 110/G	V001460
M 10 x 1	cardboard box	with 110/G + 340/GLN	V000525
M 10 x 1	cardboard box	with filler valve	V000486

75/LL Zinc

barrel version	made of zinc-plated steel Ø 56 mm (2.2")
barrel length	445 mm (17.5")
suitable for	grease up to NLGI 3
filling capacity	1,000 ccm (32 oz.) bulk grease
connection thread	M 10 x 1 or G 1/8 upon request 1/8 NPT

Connection	Packed in	Scope of delivery	Ref. No.:
M 10 x 1	polybag	without accessories	V000647
M 10 x 1	polybag	with 340/GLN	V000941
M 10 x 1	polybag	with 110/G	V001213
M 10 x 1	polybag	with 110/G + 340/GLN	V001212
M 10 x 1	polybag	with filler valve	V000938

Hand Lever Grease Gun with extended zinc-plated steel barrel

- for 500 g (17.5 oz.) grease cartridges or 600 ccm (20 oz.) bulk grease
- with UMETA TWIN-LOCK® system and EVER-FLOW system
- standard air release valve, alternatively with filler valve according to DIN 1283

operating pressure	400 bar / 5,800 PSI
output	approx. 1.9 ccm (0.06 oz.)/stroke
testing pressure	800 bar / 11,600 PSI
gun dimension	475 x 128 x 60 mm (18.7 x 5.0 x 2.36")
packed in	printed UMETA polybag or printed UMETA cardboard box
weight	net 1,450 g (51.5 oz.) + accessories and packaging

Connection	Packed in	Scope of delivery	Ref. No.:
G 1/8	polybag	without accessories	V001093
G 1/8	polybag	with 340/GLN	V001201
G 1/8	polybag	with 110/G	V001129
G 1/8	polybag	with 110/G + 340/GLN	V001200
G 1/8	polybag	with filler valve	V001198
G 1/8	cardboard box	without accessories	V001461
G 1/8	cardboard box	with 340/GLN	V001462
G 1/8	cardboard box	with 110/G	V001463
G 1/8	cardboard box	with 110/G + 340/GLN	V001464
G 1/8	cardboard box	with filler valve	V001465

Hand Lever Grease Gun with extra long zinc-plated steel barrel

- for 1,000 ccm (32.0 oz.) bulk grease
- with UMETA TWIN-LOCK® system and EVER-FLOW system
- standard air release valve, alternatively with filler valve according to DIN 1283

operating pressure	400 bar / 5,800 PSI
output	approx. 1.9 ccm (0.06 oz.)/stroke
testing pressure	800 bar / 11,600 PSI
gun dimension	552 x 128 x 60 mm (21.7 x 5.0 x 2.36")
packed in	printed UMETA polybag
weight	net 1,660 g (58.5 oz.) + accessories and packaging

Connection	Packed in	Scope of delivery	Ref. No.:
G 1/8	polybag	without accessories	V000648
G 1/8	polybag	with 340/GLN	V001233
G 1/8	polybag	with 110/G	V001232
G 1/8	polybag	with 110/G + 340/GLN	V001229
G 1/8	polybag	with filler valve	V001214

75/PKU



barrel version	made of zinc-plated steel Ø 56 mm (2.2")
barrel length	295 mm (11.6")
suitable for	grease up to NLGI 3
filling capacity	400 g (14.0 oz.) grease cartridge / 500 ccm (16.0 oz.) bulk grease
connection thread	M 10 x 1 or G 1/8 upon request 1/8 NPT

Connection	Packed in	Scope of delivery	Ref. No.:
M 10 x 1	cardboard box	without accessories	7021312
M 10 x 1	cardboard box	with 340/GLN	6800130
M 10 x 1	cardboard box	with 110/G	7751511
M 10 x 1	cardboard box	with 110/G + 340/GLN	6800140

UMETA TWIN-LOCK® Ultra Gun

top model, which combines quality, function and design

- for 400 g (14.0 oz.) grease cartridges or 500 ccm (16.0 oz.) bulk grease
- ergonomic grips made of anti-slip material
- with UMETA TWIN-LOCK® system and EVER-FLOW system
- filler valve, DIN 1283 included
- UMETA multi colour cardboard box

operating pressure	400 bar / 5,800 PSI
output	approx. 1.9 ccm (0.06 oz.)/stroke
testing pressure	800 bar / 11,600 PSI
gun dimension	400 x 135 x 75 mm (15.7 x 5.3 x 3.0")
packed in	printed UMETA cardboard box portable carrying case
weight	1,300 g (45.8 oz.) + accessories and packaging

Connection	Packed in	Scope of delivery	Ref. No.:
G 1/8	cardboard box	without accessories	7021411
G 1/8	cardboard box	with 340/GLN	7752611
G 1/8	cardboard box	with 110/G	7751611
G 1/8	cardboard box	with 110/G + 340/GLN	7759611

UMETA TWIN-LOCK® Ultra Case Kit



The complete lubricating equipment in a handy carrying case. The carrying case contains everything you need for lubricating anything, especially our **UMETA TWIN-LOCK® Ultra Grease Gun 75/PKU according to DIN 1283**. The carrying case kit comes with the practical UMETA hose parking unit. The grease gun can be hung up on the wall by the provided wall bracket, and is thus always at hand. With the many accessories, you will be prepared for any needed application.

Accessories kit, consisting of:

- hydraulic hose 340/GLN
- nozzle tube 110/G
- hydraulic coupling 515/G-4
- quick-adaptor, short version
200/M 4, 200/M 1, 200/M 22, 200/S, 200/XS
- grease nipple assortment 60s, each 5 pcs. H1/H2/H3
6 x 1, 8 x 1, 10 x 1, R 1/8
- grease cartridge 400 g (14.0 oz.)
- hose parking unit at hand lever
- wall bracket

Connection	Packaging	Scope of delivery	Ref. No.:
M 10 x 1	carrying case	complete accessories	6900096
G 1/8	carrying case	complete accessories	6900098

Ref. No.:
case without content
6900095

70/PK



The extremely light polyamide barrel with the extra band knurls ensures optimal and comfortable handling, even with cold temperatures. The robust material combines the advantages of rust-resistance and form stability, even with crashes and other impacts.

barrel version	shock-resistant polyamide barrel Ø 60 mm (2 1/8")
barrel length	292 mm (11 1/2")
suitable for	grease up to NLGI 3
filling capacity	400 g (14.0 oz.) grease cartridge/500 ccm (16.0 oz.) bulk grease
connection thread	M 10 x 1 or G 1/8 upon request 1/8 NPT

Hand Lever Grease Gun with shock-resistant polyamide barrel

- for 400 g (14.0 oz.) grease cartridges or 500 ccm (16.0 oz.) bulk grease
- with UMETA TWIN-LOCK® system and EVER-FLOW system
- standard air release valve, alternatively with filler valve according to DIN 1283

operating pressure	400 bar / 5,800 PSI
delivery capacity	approx. 1.9 ccm (0.06 oz.)/stroke
testing pressure	800 bar / 11,600 PSI
gun dimension	400 x 128 x 60 mm (15.7 x 5.0 x 2.36")
packed in	printed UMETA polybag or printed UMETA cardboard box
weight	1,000 g (35.3 oz.) + accessories and packaging

Connection	Packed in	Scope of delivery	Ref. No.:
M 10 x 1	polybag	without accessories	V000354
M 10 x 1	polybag	with 340/GLN	V000472
M 10 x 1	polybag	with 110/G	V000550
M 10 x 1	polybag	with 110/G + 340/GLN	V001002
M 10 x 1	polybag	with filler valve	V000790
M 10 x 1	cardboard box	without accessories	V000350
M 10 x 1	cardboard box	with 340/GLN	V000952
M 10 x 1	cardboard box	with 110/G	V000881
M 10 x 1	cardboard box	with 110/G + 340/GLN	V001118
M 10 x 1	cardboard box	with filler valve	V001466

Connection	Packed in	Scope of delivery	Ref. No.:
G 1/8	polybag	without accessories	V000443
G 1/8	polybag	with 340/GLN	V000637
G 1/8	polybag	with 110/G	V001095
G 1/8	polybag	with 110/G + 340/GLN	V001211
G 1/8	polybag	with filler valve	V001251
G 1/8	cardboard box	without accessories	V000645
G 1/8	cardboard box	with 340/GLN	V000842
G 1/8	cardboard box	with 110/G	V001094
G 1/8	cardboard box	with 110/G + 340/GLN	V001467
G 1/8	cardboard box	with filler valve	V001468

73/PK



barrel version	made of zinc-plated steel Ø 56 mm (2.2")
barrel length	200 mm (7.87")
suitable for	grease up to NLGI 3
filling capacity	300 ccm (10.0 oz.) bulk grease
connection thread	M 10 x 1 or G 1/8 upon request 1/8 NPT

Hand Lever Grease Gun with shortened zinc-plated steel barrel

- for 300 ccm (10.0 oz.) bulk grease
- with UMETA TWIN-LOCK® system and EVER-FLOW system
- standard air release valve, alternatively with filler valve according to DIN 1283

operating pressure	400 bar / 5,800 PSI
delivery capacity	approx. 1.9 ccm (0.06 oz.)/stroke
testing pressure	400 bar / 5,800 PSI
gun dimension	345 x 128 x 60 mm (13.6 x 5.0 x 2.36")
packed in	printed UMETA polybag or cardboard box
weight	1,075 g (37.9 oz.) + accessories and packaging

Connection	Packed in	Scope of delivery	Ref. No.:
M 10 x 1	polybag	without accessories	V000211
M 10 x 1	polybag	with 340/GLN	V000549
M 10 x 1	polybag	with 110/G	V000773
M 10 x 1	polybag	with 110/G + 340/GLN	V001220
M 10 x 1	polybag	with filler valve	V001218
M 10 x 1	cardboard box	without accessories	V000479
M 10 x 1	cardboard box	with 340/GLN	V001479
M 10 x 1	cardboard box	with 110/G	V001096
M 10 x 1	cardboard box	with 110/G + 340/GLN	V001480
M 10 x 1	cardboard box	with filler valve	V000457

Connection	Packed in	Scope of delivery	Ref. No.:
G 1/8	polybag	without accessories	V000993
G 1/8	polybag	with 340/GLN	V001227
G 1/8	polybag	with 110/G	V001054
G 1/8	polybag	with 110/G + 340/GLN	V001224
G 1/8	polybag	with filler valve	V001219
G 1/8	cardboard box	without accessories	V001481
G 1/8	cardboard box	with 340/GLN	V001024
G 1/8	cardboard box	with 110/G	V001097
G 1/8	cardboard box	with 110/G + 340/GLN	V001482
G 1/8	cardboard box	with filler valve	V000458

75/PKM



optionally available:
Gun head with
pressure release

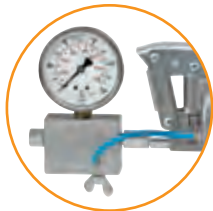

pressure gauge	pressure range up to 400 bar / 5,800 PSI alternatively with pressure range up to 1,000 bar / 14,500 PSI available with or without pressure release device
barrel version	made of zinc-plated steel special colours available Ø 56 mm (2.2")

pressure gauge up to 400 bar

Connection	Packed in	Pressure release	Ref. No.:
M 10 x 1	polybag	without	V000485
M 10 x 1	polybag	with	V000712
G 1/8	polybag	without	V000859
G 1/8	polybag	with	V000391

Hand Lever Grease Gun with pressure gauge

- pressure gauge grease gun for the exact control of the lubricating pressure in order to protect pressure-sensitive components, bearings and gaskets
- for 400 g (14.0 oz.) grease cartridges or 500 ccm (16.0 oz.) bulk grease
- with high quality zinc-plated steel barrel
- with UMETA TWIN-LOCK® system and EVER-FLOW system
- standard air release valve, alternatively with filler valve according to DIN 1283

barrel length	296 mm (11.6")
suitable for	grease up to NLGI 3
filling capacity	400 g (14.0 oz.) grease cartridge / 500 ccm (16.0 oz.) bulk grease
connection thread	M 10 x 1 or G 1/8 upon request 1/8 NPT
operating pressure	400 bar / 5,800 PSI
output	approx. 1.9 ccm (0.06 oz.)/stroke
testing pressure	800 bar / 11,600 PSI
gun dimension	480 x 130 x 60 mm (18.9 x 5.1 x 2.36")
packed in	printed UMETA polybag
weight	1,555 g (54.8 oz.) + accessories and packaging

pressure gauge up to 1,000 bar

Connection	Packed in	Pressure release	Ref. No.:
M 10 x 1	polybag	without	V000978
M 10 x 1	polybag	with	V000545
G 1/8	polybag	without	V000499
G 1/8	polybag	with	V000392

EcoLube



barrel version	blue painted steel barrel RAL 5026 Ø 56 mm (2.2")
barrel length	287 mm (11.3")
suitable for	grease up to NLGI 3
filling capacity	400 g (14.0 oz.) grease cartridge / 500 ccm (16.0 oz.) bulk grease
connection thread	M 10 x 1 or G 1/8

Connection	Packed in	Scope of delivery	Ref. No.:
M 10 x 1	polybag	without accessories	7000000
M 10 x 1	polybag	with extension tube and hydraulic coupler	7000002

Hand Lever Grease Gun

- for 400 g (14.0 oz.) grease cartridges or 500 ccm (16.0 oz.) bulk grease
- according to DIN 1283
- comes with filler valve

The light steel body, the ergonomically formed hand lever, and extra band knurls on the barrel ensure optimal handling.

operating pressure	400 bar / 5,800 PSI
output	approx. 1.4 ccm/stroke
testing pressure	600 bar / 8,700 PSI
gun dimension	390 x 120 x 55 mm (15.3 x 4.7 x 2.2")
packed in	polybag
weight	1,200 g (42.3 oz.) + accessories and packaging

Connection	Packed in	Scope of delivery	Ref. No.:
G 1/8	polybag	without accessories	7000003
G 1/8	polybag	with extension tube and hydraulic coupler	7000005

ONE-HAND GREASE GUNS

85/PK Zinc

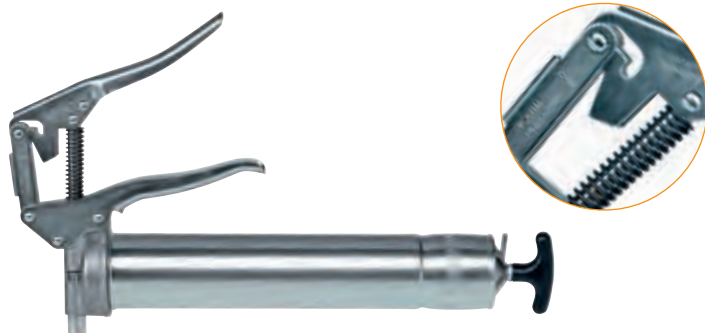

barrel version	made of zinc-plated steel, special colours available Ø 56 mm (2.2")	
barrel length	296 mm (11.6")	
suitable for	grease up to NLGI 3	
filling capacity	400 g (14.0 oz.) grease cartridge / 500 ccm (16.0 oz.) bulk grease	
connection thread	M 10 x 1 or G 1/8, upon request 1/8 NPT	
upon adjustment to:	volume	pressure
operating pressure	approx. 150 bar / 2,175 PSI	approx. 180 bar / 2,600 PSI
output	approx. 1.1 ccm/stroke	approx. 0.7 ccm/stroke

Connection	Packed in	Scope of delivery	Ref. No.:
M 10 x 1	polybag	without accessories	V000715
M 10 x 1	polybag	with 340/GLN	V000676
M 10 x 1	polybag	with 110/G	V001190
M 10 x 1	polybag	with 110/G + 340/GLN	V001189
M 10 x 1	polybag	with filler valve	V000721
M 10 x 1	cardboard box	without accessories	V000730
M 10 x 1	cardboard box	with 340/GLN	V000431
M 10 x 1	cardboard box	with 110/G	V001028
M 10 x 1	cardboard box	with 110/G + 340/GLN	V001192
M 10 x 1	cardboard box	with filler valve	V000961

One-Hand Grease Gun with high quality zinc-plated steel barrel

- for 400 g (14.0 oz.) grease cartridges or 500 ccm (16.0 oz.) bulk grease
- with UMETA TWIN-LOCK® system and EVER-FLOW system
- standard air release valve, alternatively with filler valve according to DIN 1283

This UMETA TWIN-LOCK® One-hand grease gun offers you many possibilities. The one-hand operation allows for lubricating even hard to reach spots. Our proven powerswitch system provides the opportunity to adjust the grease supply from high volume to high pressure. Just press the button on the handle, and you will obtain optimal performance.

testing pressure	200 bar / 2,900 PSI
gun dimension	403 x 170 x 60 mm (15.8 x 6.7 x 2.36")
packed in	polybag or printed UMETA cardboard box
weight	1,220 g (43.0 oz.) + accessories and packaging
dimensions (L x W x H)	405 x 172 x 77 mm

Connection	Packed in	Scope of delivery	Ref. No.:
G 1/8	polybag	without accessories	V000369
G 1/8	polybag	with 340/GLN	V000809
G 1/8	polybag	with 110/G	V001195
G 1/8	polybag	with 110/G + 340/GLN	V001194
G 1/8	polybag	with filler valve	V001187
G 1/8	cardboard box	without accessories	V000548
G 1/8	cardboard box	with 340/GLN	V000858
G 1/8	cardboard box	with 110/G	V001157
G 1/8	cardboard box	with 110/G + 340/GLN	V001196
G 1/8	cardboard box	with filler valve	V001188

85/PK Silver



Connection	Packed in	Scope of delivery	Ref. No.:
M 10 x 1	polybag	without accessories	V000382
M 10 x 1	polybag	with 340/GLN	V000538
M 10 x 1	polybag	with 110/G	V000997
M 10 x 1	polybag	with 110/G + 340/GLN	V001469
M 10 x 1	polybag	with filler valve	V000772
M 10 x 1	cardboard box	without accessories	V000210
M 10 x 1	cardboard box	with 340/GLN	V000507
M 10 x 1	cardboard box	with 110/G	V001136
M 10 x 1	cardboard box	with 110/G + 340/GLN	V001470
M 10 x 1	cardboard box	with filler valve	V000454

* special version USA

One-Hand Grease Gun with high quality silver painted steel barrel

- for 400 g (14.0 oz.) grease cartridges or 500 ccm (16.0 oz.) bulk grease
- with UMETA TWIN-LOCK® system and EVER-FLOW system
- standard air release valve, alternatively with filler valve according to DIN 1283

Technical details above.

Connection	Packed in	Scope of delivery	Ref. No.:
G 1/8	polybag	without accessories	V000371
G 1/8	polybag	with 340/GLN	V001471
G 1/8	polybag	with 110/G	V000768
G 1/8	polybag	with 110/G + 340/GLN	V001472
G 1/8	polybag	with filler valve	V000704
G 1/8	cardboard box	without accessories	V000420
G 1/8	cardboard box	with 340/GLN	V001473
G 1/8	cardboard box	with 110/G	V000771
G 1/8	cardboard box	with 110/G + 340/GLN	V001474
G 1/8	cardboard box	with filler valve	V000421
1/8 NPT	polybag	without accessories	V000617
1/8 NPT	cardboard box	with filler valve*	V000640

AIR-OPERATED GREASE GUNS

DRP 30

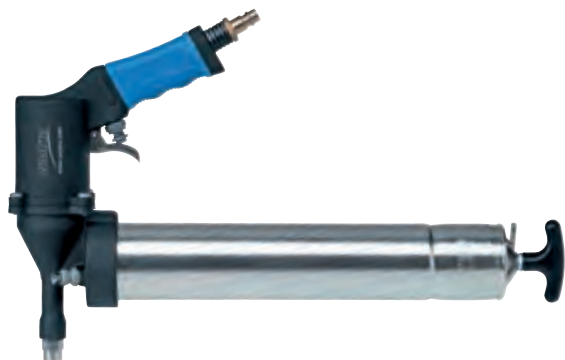

Inclusive extension tube and hose with hydraulic coupler



Air-operated grease gun

- for 400 g (14.0 oz.) grease cartridges or 500 ccm (16.0 oz.) bulk grease
- continuous grease flow
- extra light and handy due to aluminium body with ergonomic handle
- compressed air connection for quick coupling
- comes with nozzle tube and HP hose according to DIN 1283
- comes with air release valve and separate filler valve (DIN standard)



barrel version	made of zinc-plated steel DIN 1283 special colours available Ø 56 mm (2.2")
barrel length suitable for filling capacity	296 mm (11.6") grease up to NLGI 3 400 g (14.0 oz.) grease cartridge / 500 ccm (16.0 oz.) bulk grease
standard valve	air release valve and separate filler valve (DIN standard)
connection thread	G 1/8
pressure ratio	40:1
air pressure	3 – 7 bar, 43.5 – 100 PSI; recommended air pressure 6 bar/90 PSI

operating pressure	280 bar / 4,060 PSI max.
output	approx. 500 ccm/3 min. or 160 ccm (5.1 oz.)/min.
testing pressure	320 bar (4,640 PSI)
gun dimension	405 x 260 x 60 mm (15.9 x 10.2 x 2.36")
packed in	printed UMETA multi colour cardboard box
weight	1,385 g (48.8 oz.) + packaging
dimensions (L x W x H)	425 x 185 x 80 mm (16.7 x 7.3 x 3.15")

Connection	Packed in	Scope of delivery	Ref. No.:
G 1/8	cardboard box	complete with accessories: - HP hose Ø 13 (1/2") mm, 300 mm (12") length - nozzle tube 110/G each with hydraulic coupler	7437505

PUSH-TYPE AND SCREW-TYPE GREASE GUNS

The UMETA programme offers the optimal solution for all lubricating needs. Either with shock-resistant polyamide bodies, or made of high quality zinc-plated steel, with or without telescopic tube: you will find the right push-type grease guns for all sizes and requirements.

Push-type grease guns stand out for their handiness and easy operability. Light pressure suffices to allow for the effective lubrication of hydraulic nipples, ball-type and flush-type nipples. The UMETA telescopic push-type grease guns are equipped with a telescopic tube and are therefore suitable for harder to reach applications.

With our nozzles, you will find the optimal connection to any lubricating nipple according to DIN. UMETA push-type grease guns are equipped with special nozzles M 9 x 1. Just choose the desired push-type grease gun with the suitable nozzle for your lubricating nipple type from the list!



Model 30 – 34



barrel version
suitable for
connection thread
packaging

shock-resistant polyamide gun body
grease up to NLGI2
M 9 x 1
bulk

Type	Connection M 9 x 1	Ref. No.:
30	hollow-type nozzle 500	7130433
30/S	pointed nozzle 500/S	7130133
30/H	hydraulic nozzle 500/H	7130233
30/NS	pin pointed nozzle 500/NS	7130533
30/K	combi nozzle 500/K	7133933

Push-Type Grease Gun made of shock-resistant polyamide

- form B according to DIN 1282
- suitable for hydraulic, ball-type, and flush-type nipples

	Type 30	Type 34
filling capacity	60 ccm (2.0 oz.)	150 ccm (4.8 oz.)
operating pressure (approx.)	80 – 120 bar	80 – 120 bar
output per stroke	0.6 ccm (0.02 oz.)	0,6 ccm (0.02 oz.)
total length	165 mm (6 1/2")	200 mm (7 7/8")
tube measurements (Ø x L)	30 x 105 mm (1.18" x 4.13")	42 x 140 mm (1.66" x 5.5")
weight	62 g (2.2 oz.)	100 g (3.5 oz.)

Type	Connection M 9 x 1	Ref. No.:
34	hollow-type nozzle 500	7134433
34/S	pointed nozzle 500/S	7134133
34/H	hydraulic nozzle 500/H	7134233
34/NS	pin pointed nozzle 500/NS	7134533
34/K	combi nozzle 500/K	7135933

Model 36



barrel version zinc-plated body
 suitable for grease up to NLGI2
 filling capacity 300 ccm (10.0 oz.) bulk grease
 connection thread M 9 x 1
 operating pressure approx. 120 – 200 bar / 1,740 – 2,900 PSI

Type	Connection M 9 x 1	Ref. No.:
36	hollow-type nozzle 500	7136413
36/S	pointed nozzle 500/S	7136113
36/H	hydraulic nozzle 500/H	7136213

Push-Type Grease Gun made of zinc-plated steel

- form B according to DIN 1282
- suitable for hydraulic, ball-type, and flush-type nipples

output 0.7 ccm (0.02 oz.)/stroke
 tube measurements Ø 50 mm x L 155 mm (Ø 1.97" x L 6.1")
 barrel length 240 mm (9 ½")
 packaging bulk
 weight 300 g (10.5 oz.)

Type	Connection M 9 x 1	Ref. No.:
36/NS	pin pointed nozzle 500/NS	7136313
36/K	combi nozzle 500/K	7136513

Model 40 – 44



barrel version shock-resistant polyamide gun body
 suitable for grease up to NLGI2
 connection thread M 9 x 1
 packaging bulk

Type	Connection M 9 x 1	Ref. No.:
40	hollow-type nozzle 500	7140433
40/S	pointed nozzle 500/S	7140133
40/H	hydraulic nozzle 500/H	7140233
40/NS	pin pointed nozzle 500/NS	7140333
40/K	combi nozzle 500/K	7140533

Type	Connection M 9 x 1	Ref. No.:
42	hollow-type nozzle 500	7142433
42/S	pointed nozzle 500/S	7142133
42/H	hydraulic nozzle 500/H	7142233
42/NS	pin pointed nozzle 500/NS	7142533
42/K	combi nozzle 500/K	7142733

Telescopic Push-Type Grease Gun made of polyamide

- form A according to DIN 1282
- with telescopic tube
- suitable for hydraulic, ball-type, and flush-type nipples

	Type 40	Type 42	Type 44
filling capacity bulk grease	70 ccm (2.4 oz.)	110 ccm (3.5 oz.)	180 ccm (5.8 oz.)
operating pressure (approx.)	140 bar / 2,030 PSI	180 bar / 2,610 PSI	200 bar / 2,900 PSI
output per stroke	0.8 – 1.2 ccm (0.03 – 0.04 oz.)	0.8 – 1.2 ccm (0.03 – 0.04 oz.)	0.8 – 1.2 ccm (0.03 – 0.04 oz.)
total length	240 mm (9 1/2")	270 mm (10 1/2")	335 mm (13 1/2")
tube measurements (Ø x L)	36 x 100 mm (0.42" x 3.94")	41 x 110 mm (1.62" x 4.33")	45 x 135 mm (1.78" x 5.31")
weight	100 g (3.5 oz.)	120 g (4.25 oz.)	150 g (5.3 oz.)

Type	Connection M 9 x 1	Ref. No.:
44	hollow-type nozzle 500	7144433
44/S	pointed nozzle 500/S	7144133
44/H	hydraulic nozzle 500/H	7144233
44/NS	pin pointed nozzle 500/NS	7144533
44/K	combi nozzle 500/K	7144733

Model 46



barrel version zinc-plated body
suitable for grease up to NLGI2
filling capacity 335 ccm (10.7 oz.) bulk grease
connection thread M 9 x 1
operating pressure approx. 200 bar / 2,900 PSI

Type	Connection M 9 x 1	Ref. No.:
46	hollow-type nozzle 500	7146413
46/S	pointed nozzle 500/S	7146113
46/H	hydraulic nozzle 500/H	7146213

Telescopic Push-Type Grease Gun made of zinc-plated steel

- form A according to DIN 1282
- with telescopic tube
- suitable for hydraulic, ball-type, and flush type nipples

output approx. 1.2 ccm (0.04 oz.)/stroke
tube measurements Ø 45 mm x L 250 mm (Ø 1.8" x L 9.8")
total length 565 mm (22 ¼")
packaging bulk
weight 600 g (21 oz.)

Type	Connection M 9 x 1	Ref. No.:
46/NS	pin pointed nozzle 500/NS	7146313
46/K	combi nozzle 500/K	7146753

Model 21



barrel version zinc-plated body
suitable for grease up to NLGI2
filling capacity 150 ccm (4.8 oz.)
connection thread M 10 x 1 or R 1/8
operating pressure approx. 8 – 20 bar / 116 – 290 PSI

Connection	Scope of delivery	Ref. No.:
M 10 x 1	without accessories	7611113

Screw-Type Grease Gun made of zinc-plated steel

- metering gun for greases

output approx. 1.8 ccm (0.06 oz.)/turn
tube measurements Ø 40 mm x L 130 mm (Ø 1.6" x L 5.1")
total length 180 mm (7")
packaging bulk
weight 365 g (12.9 oz.)

Connection	Scope of delivery	Ref. No.:
R 1/8	without accessories	7611213

OIL GUNS

UMETA oil guns are specially designed for operation with oils and high-viscosity grease, and they are manufactured with the same high quality as the well-established UMETA grease guns. Sealing elements and accessory parts specially designed for this purpose allow for optimal leakproof oil fittings.

70/PKO



barrel version	shock-resistant polyamide barrel Ø 60 mm (2 1/8")
barrel length	292 mm (11 1/2")
suitable for	oils and high-viscosity grease
filling capacity	500 ccm (16.0 oz.) bulk grease and oil
connection thread	M 10 x 1 or G 1/8 upon request 1/8 NPT
operating pressure	400 bar / 5,800 PSI

Hand Lever Oil Guns with shock-resistant polyamide barrel

- for 500 ccm (16.0 oz.) oil

We recommend our wall hook, Ref. No. 6900099 for a proper and leakproof storage of the oil gun after use.



output	approx. 1.9 ccm (0.06 oz.)/stroke
testing pressure	800 bar / 11,600 PSI
packed in	printed UMETA polybag or printed UMETA cardboard box
weight	1,075 g (37.9 oz.) + accessories and packaging

Connection	Packed in	Scope of delivery	Ref. No.:
M 10 x 1	polybag	without accessories	V001549
M 10 x 1	polybag	with 340/GLN, incl. oil hydraulic coupling	V001502
M 10 x 1	polybag	with 110/GO	V001550
M 10 x 1	cardboard box	without accessories	V001554
M 10 x 1	cardboard box	with 340/GLN, incl. oil hydraulic coupling	V001555
M 10 x 1	cardboard box	with 110/GO	V001557

Connection	Packed in	Scope of delivery	Ref. No.:
R 1/8	polybag	without accessories	V001551
R 1/8	polybag	with 340/GLN, incl. oil hydraulic coupling	V001553
R 1/8	polybag	with 110/GO	V001552
R 1/8	cardboard box	without accessories	V001558
R 1/8	cardboard box	with 340/GLN, incl. oil hydraulic coupling	V001559
R 1/8	cardboard box	with 110/GO	V001560

43/S and 43/H



43/S



43/H

barrel version	shock-resistant polyamide barrel
tube measurements (Ø x L)	41 x 110 mm (1 5/8" x 4 1/8")
total length	270 mm (10 5/8")
suitable for	oils and high-viscosity grease
filling capacity	110 ccm (3.5 oz.)
connection thread	M 9 x 1

Telescopic Push Type Oil Guns

- form A according to DIN 1282
- suitable for oils and high-viscosity grease
- comes with pointed nozzle or hydraulic nozzle

The UMETA telescopic push-type oil guns are equipped with a telescopic tube and are therefore suitable for a precise lubrication. Light pressure suffices to allow for the effective lubrication of hydraulic nipples, ball-type and flush-type nipples.

operating pressure	180 bar (2,610 PSI)
output	0.6 ccm (0.02 oz.)/stroke
packaging	bulk
weight	120 g (4.2 oz.) + accessories and packaging

Type	Scope of delivery	Ref. No.:
43/S	pointed nozzle 500/S	7143133

Type	Scope of delivery	Ref. No.:
43/H	hydraulic nozzle 500/H	7143233

ACCESSORIES FOR GREASE GUNS

UMETA original accessories for grease guns offer a wide range of application possibilities. Therefore, you will be able to solve any lubricating needs with our accessories.

If not, we as an experienced manufacturer, will find a solution together with you.

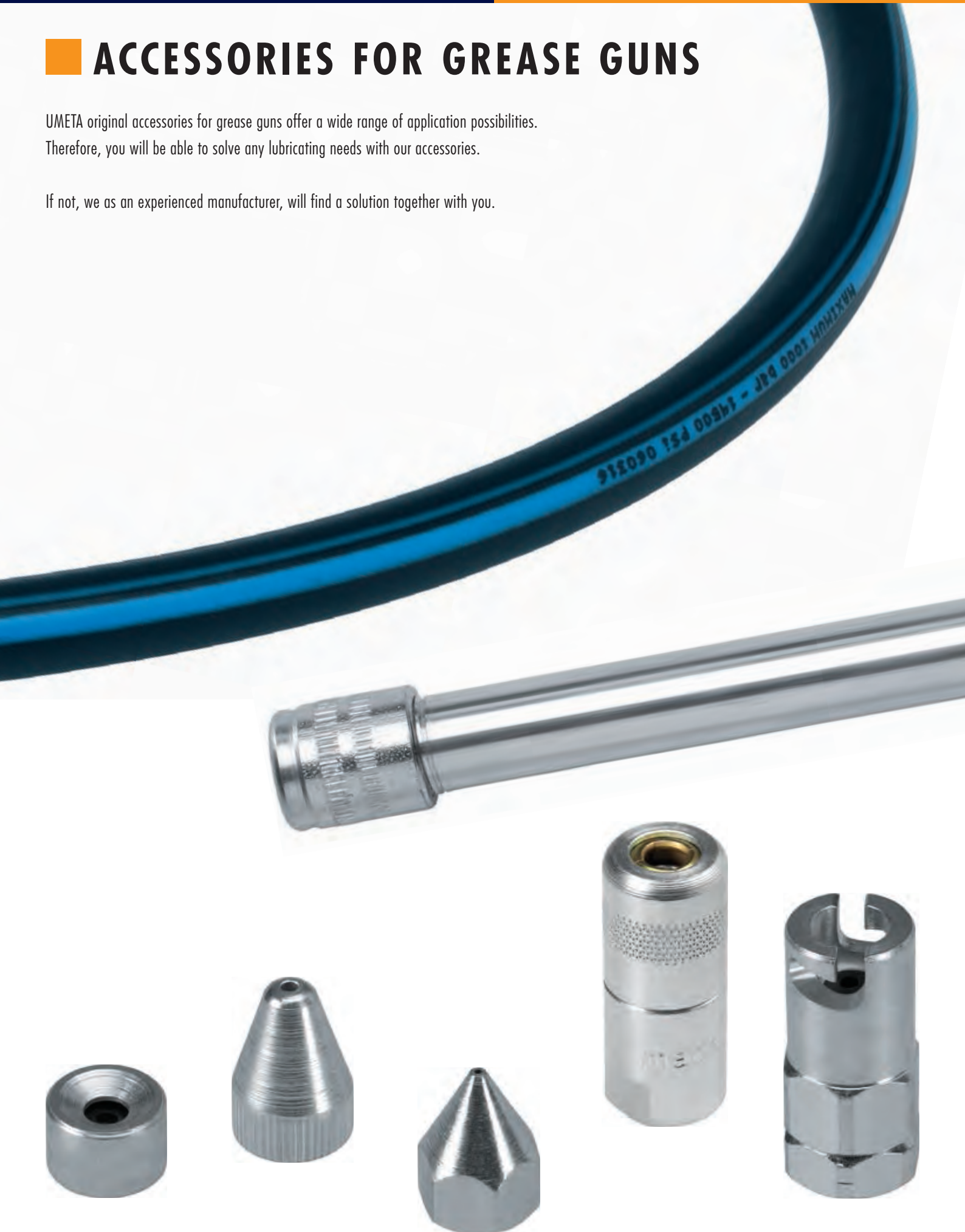

NOZZLE TUBES

UMETA nozzle tubes in a straight or bent version allow for most simple, tool-free assembly by a polyamide butterfly nut, which guarantees an optimal sealing effect and which makes it possible to stabilize the bent nozzle in any desired position.

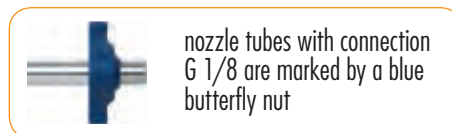

► nozzle tubes with connection thread 1/8-NPT upon request

110/G



- nozzle tube, bent
- with hydraulic coupler
- length 170 mm

Type	Connection	Ref. No.:
110/G	M 10 x 1	V000279
110/G	G 1/8	V000337

100/G



- nozzle tube, straight
- with hydraulic coupler
- length 170 mm

Type	Connection	Ref. No.:
100/G	M 10 x 1	V000044
100/G	G 1/8	V000155

110/S



- nozzle tube, bent
- with pointed nozzle
- length 154 mm

Type	Connection	Ref. No.:
110/S	M 10 x 1	V000316
110/S	G 1/8	V000285

100/S



- nozzle tube, straight
- with pointed nozzle
- length 154 mm

Type	Connection	Ref. No.:
100/S	M 10 x 1	V000247
100/S	G 1/8	V000253

110/H



- nozzle tube, bent
- with hydraulic nozzle
- length 150 mm

Type	Connection	Ref. No.:
110/H	M 10 x 1	V000103
110/H	G 1/8	V000375

100/H



- nozzle tube, straight
- with hydraulic nozzle
- length 150 mm

Type	Connection	Ref. No.:
100/H	M 10 x 1	V000076
100/H	G 1/8	V000055

95/G



- nozzle tube, bent
- without butterfly nut
- with hydraulic coupler
- length 170 mm (6 1/2")

Type	Connection	Ref. No.:
95/G	M 10 x 1	V000398
95/G	G 1/8	V000154
95/G	1/8 NPT	V000101

90/G



- nozzle tube, straight
- without butterfly nut
- with hydraulic coupler
- length 170 mm (6 1/2")

Type	Connection	Ref. No.:
90/G	M 10 x 1	V000074
90/G	G 1/8	V000054
90/G	1/8 NPT	V000072

NOZZLES AND HYDRAULIC COUPLERS

Hollow-type nozzle



- suitable for ball-type and hydraulic-type nipples acc. to DIN 71412

outer Ø 12 mm
height 8.5 mm

Type	Connection	Ref. No.:
500	M 9 x 1	7351461
501	M 10 x 1	V000100
502	G 1/8	V000227

Pointed nozzle



- suitable for flush-type nipples acc. to DIN 3405

outer Ø 12 mm
height 18 mm

Type	Connection	Ref. No.:
500/S	M 9 x 1	7351161
501/S	M 10 x 1	V000248
502/S	G 1/8	V000254

Pin pointed nozzle



- suitable for flush-type nipples acc. to DIN 3405

height 16 mm
spanner size 11

Type	Connection	Ref. No.:
500/NS	M 9 x 1	7351561
501/NS	M 10 x 1	V000246
502/NS	G 1/8	V000252

Hydraulic nozzle



- suitable for ball-type and hydraulic-type nipples acc. to DIN 71412

outer Ø 12 mm
height 15 mm

Type	Connection	Ref. No.:
500/H	M 9 x 1	7351261
501/H	M 10 x 1	V000104
502/H	G 1/8	V000250

Combo-nozzle hollow/pointed



- suitable for two different applications by just unscrewing/screwing the desired nozzle

outer Ø 12 mm
height 28 mm
spanner size 11

Type	Connection	Ref. No.:
500/K	M 9 x 1	7351061
501/K	M 10 x 1	7351031
502/K	G 1/8	7351041

Hydraulic coupler



also available with turned jaws upon request



- standard with 4 punched jaws
- suitable for hydraulic-type nipples acc. to DIN 71412

outer Ø 15 mm
height 36 mm
spanner size 13

Type	Connection	Ref. No.:
515/G	M 9 x 1	7353361
515/G	M 10 x 1	V000077
515/G	G 1/8	V000106
515/G	1/8 NPT	V000102

Angled hydraulic coupler



- standard with 4 punched jaws
- suitable for hydraulic-type nipples acc. to DIN 71412

outer Ø 15 mm
height 36 mm
width 27 mm
spanner size 14

Type	Connection	Ref. No.:
515/G-S	M 10 x 1	7351314
515/G-S	G 1/8	7351315
515/G-S	1/8 NPT	7351317

Hydraulic coupler, heavy-duty hexagon



- standard with 4 punched jaws
- suitable for hydraulic-type nipples acc. to DIN 71412

· with ball valve
· oil-proof
outer Ø 15 mm
height 48 mm
spanner size 17

Type	Connection	Ref. No.:
512/G	M 10 x 1	7351316
512/G	G 1/8	7351326
512/G	1/8 NPT	7351376

Bayonet coupler



- suitable for bayonet nipples

outer Ø 16.5 mm
height 37 mm
spanner size 17

Type	Connection	Ref. No.:
517/B	M 10 x 1	9140215
517/B	G 1/8	9140216
517/B	1/8 NPT (upon request)	9140217

Button-head coupler



The UMETA slide coupler is equipped with the hose connection either at the top, or at the side – and it is made of aluminium or steel for optimal handling – according to each application. You achieve additional flexibility by using a swivel joint.

· according to DIN 1283

Sidewise connection



Dimensions	M 4	M 1 + T 1	M 22
outer Ø	18.0 mm	24.0 mm	32.0 mm
height	28.5 mm	28.0 mm	38.5 mm
width	31.0 mm	36.0 mm	42.0 mm

Top connection



Dimensions	M 1 + T 1	M 22
outer Ø	24.0 mm	32.0 mm
height	28.0 mm	38.5 mm

Type	Connection	Sidewise	Aluminium	Steel
520	M 10 x 1	M 4, Ø 10 mm	—	V000088
521	M 10 x 1	M 1 + T 1, Ø 16 mm	V000097	V000084
522	M 10 x 1	M 22, Ø 22 mm	V000095	V000096
520	G 1/8	M 4, Ø 10 mm	—	V000085
521	G 1/8	M 1 + T 1, Ø 16 mm	V000331	V000224
522	G 1/8	M 22, Ø 22 mm	V000098	V000321
520	1/8 NPT	M 4, Ø 10 mm	—	V001625
521	1/8 NPT	M 1 + T 1, Ø 16 mm	V000325	V001425
522	1/8 NPT	M 22, Ø 22 mm	V000666	V001426

Type	Connection	Top	Aluminium	Steel
520	M 10 x 1	M 4, Ø 10 mm	—	—
521	M 10 x 1	M 1 + T 1, Ø 16 mm	—	7368015
522	M 10 x 1	M 22, Ø 22 mm	—	—
520	G 1/8	M 4, Ø 10 mm	—	—
521	G 1/8	M 1 + T 1, Ø 16 mm	—	—
522	G 1/8	M 22, Ø 22 mm	7368011	7368012

▶ Sealing kits for slide coupler, consisting of sealing, spring, and metal ring, are available in different versions and sizes.

▶ Further special versions upon request, e. g. those for using resins.

▶  Button-head coupler with connection possibility on both sides upon request.

Swivel joint



For a flexible assembly between hose and coupler, we recommend using a UMETA swivel joint. With a UMETA swivel joint, the coupler can be turned to any desired position without having to hold the grease gun in an inappropriate position.

length	30 mm
weight	11 g
outer Ø	14 mm
spanner size	14

Type	Connection	Ref. No.:
140/G20	M 10 x 1	7331911
140/G20	G 1/8	7331921
140/G20	G 1/4	7331941
140/G20	1/8 NPT	7331925

OIL-PROOF HYDRAULIC COUPLER

Hydraulic coupler



- with ball valve – therefore, absolutely oil-proof
- suitable for hydraulic-type nipples acc. to DIN 71412

- standard with 4 punched jaws

outer Ø	15 mm
height	36 mm
spanner size	13

Type	Connection	Ref. No.:
515/G0	M 10 x 1	V000330
515/G0	G 1/8	V000361
515/G0	1/8 NPT	V000239

Hydraulic coupler, heavy-duty hexagon



- with ball valve – therefore, absolutely oil-proof
- suitable for hydraulic-type nipples acc. to DIN 71412

- standard with 4 punched jaws

outer Ø	15 mm
height	48 mm
spanner size	17

Type	Connection	Ref. No.:
512/G	M 10 x 1	7351316
512/G	G 1/8	7351326
512/G	1/8 NPT	7351376

HIGH PRESSURE HOSES

With UMETA's hoses, you establish an optimal connection between your grease gun and the lubricating spot. Available in two versions and lengths, either without nozzle, or already assembled with the UMETA nozzle of your choice.

360/LN



inner Ø	4.0 mm (0.16")
outer Ø	10.2 mm (0.4")
burst pressure	1,000 bar / 14,500 PSI
testing pressure	800 bar / 11,600 PSI
operating pressure max.	400 bar / 5,800 PSI

Type	Connection	Connector	Length	Ref. No.:
360/LN	M 10 x 1	without nozzle	300 mm (12")	V000145
340/GLN	M 10 x 1	hydraulic coupler H	300 mm (12")	V000039
330/LN	M 10 x 1	button head coupler M 4	300 mm (12")	V000366
350/LN	M 10 x 1	button head coupler M 1 + T 1	300 mm (12")	V000283
354/LN	M 10 x 1	button head coupler M 22	300 mm (12")	V000318
360/LN	G 1/8	without nozzle	300 mm (12")	V000130
340/GLN	G 1/8	hydraulic coupler H	300 mm (12")	V000108
330/LN	G 1/8	button head coupler M 4	300 mm (12")	V001048
350/LN	G 1/8	button head coupler M 1 + T 1	300 mm (12")	V000223
354/LN	G 1/8	button head coupler M 22	300 mm (12")	V000650
360/LN	1/8" NPT	without nozzle	300 mm (12")	V000109
340/GLN	1/8" NPT	hydraulic coupler H	300 mm (12")	V000326
330/LN	1/8" NPT	button head coupler M 4	300 mm (12")	V001662
350/LN	1/8" NPT	button head coupler M 1 + T 1	300 mm (12")	V000682
354/LN	1/8" NPT	button head coupler M 22	300 mm (12")	V000683

360/L



inner Ø	4.8 mm (0.19")
outer Ø	12.5 mm (0.5")
burst pressure	1,650 bar / 23,925 PSI
testing pressure	800 bar / 11,600 PSI
operating pressure max.	415 bar / 6,000 PSI

Type	Connection	Connector	Length	Ref. No.:
360/L	M 10 x 1	without nozzle	300 mm (12")	V000282
340/GL	M 10 x 1	hydraulic coupler H	300 mm (12")	V000200
330/L	M 10 x 1	slide coupler M 4	300 mm (12")	V001206
350/L	M 10 x 1	slide coupler M 1 + T 1	300 mm (12")	V000311
354/L	M 10 x 1	slide coupler M 22	300 mm (12")	V000653
360/L	G 1/8	without nozzle	300 mm (12")	V000410
340/GL	G 1/8	hydraulic coupler H	300 mm (12")	V000042
330/L	G 1/8	slide coupler M 4	300 mm (12")	V001208
350/L	G 1/8	slide coupler M 1 + T 1	300 mm (12")	V000741
354/L	G 1/8	slide coupler M 22	300 mm (12")	V000761
360/L	1/8" NPT	without nozzle	300 mm (12")	V000521
340/GL	1/8" NPT	hydraulic coupler H	300 mm (12")	V000686
330/L	1/8" NPT	slide coupler M 4	300 mm (12")	V001672
350/L	1/8" NPT	slide coupler M 1 + T 1	300 mm (12")	V000687
354/L	1/8" NPT	slide coupler M 22	300 mm (12")	V000688

Please be aware of smallest allowable bending radius.

ATTENTION: NEVER FOLD!

High pressure hose Ø 11 mm (0.43")

· DIN 1283

temperature range	-20°C – +60°C (-4 °F – +140 °F)
allowed bending radius max.	35 mm (1.37")
inner layer	polyethylene
reinforcement	1 polyester insert
outer layer	polyamide

Type	Connection	Connector	Length	Ref. No.:
362/LN	M 10 x 1	without nozzle	500 mm (20")	V000312
342/GLN	M 10 x 1	hydraulic coupler H	500 mm (20")	V000041
332/LN	M 10 x 1	button head coupler M 4	500 mm (20")	V000940
352/LN	M 10 x 1	button head coupler M 1 + T 1	500 mm (20")	V000298
356/LN	M 10 x 1	button head coupler M 22	500 mm (20")	V000394
362/LN	G 1/8	without nozzle	500 mm (20")	V000323
342/GLN	G 1/8	hydraulic coupler H	500 mm (20")	V000288
332/LN	G 1/8	button head coupler M 4	500 mm (20")	V001049
352/LN	G 1/8	button head coupler M 1 + T 1	500 mm (20")	V000651
356/LN	G 1/8	button head coupler M 22	500 mm (20")	V000652
362/LN	1/8" NPT	without nozzle	500 mm (20")	V000328
342/GLN	1/8" NPT	hydraulic coupler H	500 mm (20")	V000327
332/LN	1/8" NPT	button head coupler M4	500 mm (20")	V001663
352/LN	1/8" NPT	button head coupler M 1 + T 1	500 mm (20")	V000684
356/LN	1/8" NPT	button head coupler M 22	500 mm (20")	V000685

high pressure hose 2 SN Ø 13 mm (½")

· DIN 1283

temperature range:	-40°C – +100°C (-40 °F – +212 °F)
allowed bending radius max.:	90 mm (3.5")
inner layer	polyethylene
reinforcement	double steel wire braid
outer layer	synth. rubber

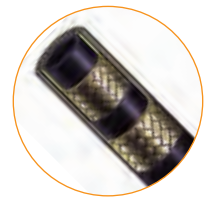

Type	Connection	Connector	Length	Ref. No.:
362/L	M 10 x 1	without nozzle	500 mm (20")	V000297
342/GL	M 10 x 1	hydraulic coupler H	500 mm (20")	V000294
332/L	M 10 x 1	slide coupler M 4	500 mm (20")	V001207
352/L	M 10 x 1	slide coupler M 1 + T 1	500 mm (20")	V000475
356/L	M 10 x 1	slide coupler M 22	500 mm (20")	V000332
362/L	G 1/8	without nozzle	500 mm (20")	V000471
342/GL	G 1/8	hydraulic coupler H	500 mm (20")	V000496
332/L	G 1/8	slide coupler M 4	500 mm (20")	V001209
352/L	G 1/8	slide coupler M 1 + T 1	500 mm (20")	V001210
356/L	G 1/8	slide coupler M 22	500 mm (20")	V001020
362/L	1/8" NPT	without nozzle	500 mm (20")	V000465
342/GL	1/8" NPT	hydraulic coupler H	500 mm (20")	V000689
332/L	1/8" NPT	slide coupler M 4	500 mm (20")	V001673
352/L	1/8" NPT	slide coupler M 1 + T 1	500 mm (20")	V000490
356/L	1/8" NPT	slide coupler M 22	500 mm (20")	V000691

QUICK-ADAPTERS

- for high pressure hoses and nozzle tubes with hydraulic coupler

Quick-adapter, short



- allows for the flexible combination with various UMETA accessory parts

length 32 mm
weight 45 g
outer Ø 20 mm

Connection	Ref. No.:
M 8 x 1	9907126
M 10 x 1	9907127
R 1/8	9907128

200/M 1



- for button-head nipples M 1 (Ø 16) acc. to DIN 3404
- button-head coupler made of aluminium

length 105 mm
height 28 mm
weight 110 g
outer Ø 24 mm

Type	Ref. No.:
200/M 1	7321651

200/M 4



- for button-head nipples M 4 (Ø 10) acc. to DIN 3404
- button-head coupler made of steel

length 107 mm
height 28.5 mm
weight 100 g
outer Ø 18 mm

Type	Ref. No.:
200/M 4	7321851

200/M 22



- for button-head nipples M 22 (Ø 22) acc. to DIN 3404
- button-head coupler made of aluminium

length 114 mm
height 38.5 mm
weight 160 g
outer Ø 32 mm

Type	Ref. No.:
200/M 22	7321751

200/K



- for cardan shafts, with hollow nozzle

length 133 mm
weight 80 g

Type	Ref. No.:
200/K	7322451

200/S



- for flush-type nipples acc. to DIN 3405

length 92 mm
weight 65 g

Type	Ref. No.:
200/S	7321151

200/XS



- hard to reach areas, for cardan shafts and smallest nipples of any kind

length 95 mm
weight 60 g
pin point tube
outer Ø 4 mm
inner Ø 0.8 mm
length 55 mm

Type	Ref. No.:
200/XS	7321551

Quick-adapters in a handy carrying case



consisting of:

- each 1 x 200/M 1
- 200/M 4
- 200/M 22
- 200/K
- 200/S
- 200/XS
- swivel joint

	Ref. No.:
	9230004

WALL BRACKETS

- Wall bracket for UMETA TWIN-LOCK® Grease Guns



With the robust wall bracket made of zinc plated steel you obtain a steady-state greasing station for your UMETA grease gun.

After having mounted the bracket to the wall, the grease gun will be fixed with the clamping collar.

Now, the grease nipple has to be connected with hose and nozzle and can be lubricated very comfortable directly from the wall station.

For changing the grease cartridge the gun tube can be removed while the grease gun remains in the bracket.

Type	Ref. No.:
Wall bracket (open version), cpl. set	7092100
Wall bracket (closed version), cpl. set	7092110
Wall hook	6900099

GREASE CARTRIDGES

UMETA grease cartridges according to DIN 1284



filling quantity	400 g (14.0 oz.)
thaw point	180 °C/356 °F
NLGI class	2
packing unit	24 pcs.

Super lithium multipurpose grease

- cartridge according to DIN 1284
- suitable for lubricating normally strained bearings
- suitable for all grease guns according to DIN 1283
- universally applicable

application temperature	-30 °C/ -22 °F up to +120 °C/ 248 °F
upon permanent operation	
temporarily	up to +130 °C/266 °F

Packing unit	Ref. No.:
24 pcs.	7371953

■ GARAGE EQUIPMENT

Get the practical devices for daily works in the garage from UMETA as well!

We offer you the complete programme of handling systems, such as suction and filling devices, or fully equipped grease gun carrying cases, e. g.



■ SUCTION GUNS

Suction Guns are practical and reliable devices for suction and delivery of oils and high-viscosity grease. They stand out by their ergonomic handle, robust design, and they are easy to operate.

For an optimal sealing effect, they are always equipped with a double sleeve. Here, too, we carry a complete accessories programme, e. g. connection nozzle tubes and flexible hoses.



Type 2



barrel version	made of zinc-plated steel
	Ø 42 mm (1.65")
barrel length	260 mm (10.2")
suitable	for oil and high-viscosity grease
filling capacity	250 ccm (8.75 oz.)
connection thread	M 10 x 1

Connection	Ref. No.:
M 10 x 1	7222143

Suction Gun

- for a 250 ccm content

packed in	polybag or bulk
weight	440 g (15.5 oz.) + accessories and packaging
dimensions	42 x 290 mm (1.65" x 11.4")

Type 3



barrel version	zinc-plated steel, yellow passivated
	Ø 50 mm (2.0")
barrel length	295 mm (11.6")
suitable	for oil and high-viscosity grease
filling capacity	500 ccm (17.5 oz.)
connection thread	M 10 x 1

Connection	Ref. No.:
M 10 x 1	7233113

Suction Gun

- for a 500 ccm content

packed in	polybag or bulk
weight	560 g (19.8 oz.) + accessories and packaging
dimensions	56 x 350 mm (2.2" x 13.8")

Type 4



barrel version	zinc-plated steel, yellow passivated
	Ø 56 mm (2.2")
barrel length	446 mm (17.6")
suitable	for oil and high-viscosity grease
filling capacity	1,000 ccm (35.0 oz.)
connection thread	M 13 x 1

Suction Gun

· for a 1,000 ccm content

packed in	polybag or bulk
weight	1,065 g (37.6 oz.) + accessories and packaging
dimensions	61 x 530 mm (2.4" x 20.9")

Connection

M 13 x 1

Ref. No.:

7244313

Type 2/V

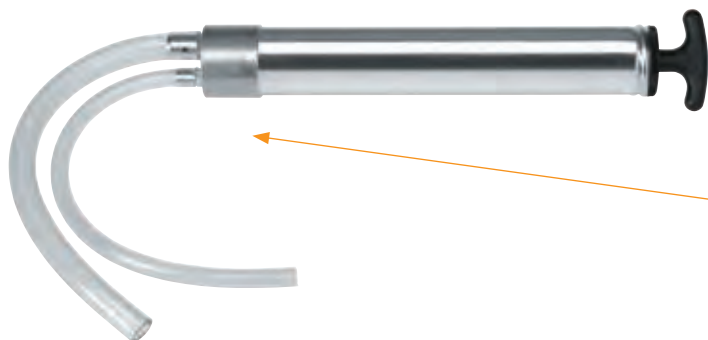

Suction Gun with reversing valve

· for a 250 ccm content

The reversing valve of type 2/V allows for most simple transfer of liquids from one container to another.

barrel version	made of zinc-plated steel
	Ø 42 mm (1.65")
barrel length	270 mm (10.6")
suitable	for oil and high-viscosity grease
filling capacity	250 ccm (8.75 oz.)

packed in	polybag or bulk
weight	580 g (20.5 oz.) + packaging
dimensions	42 x 360 mm (1.65" x 14.2")

Ref. No.:

7212443

Filling cylinder



barrel version	made of zinc-plated steel
	Ø 56 mm (2.2")
barrel length	370 mm (14.6")
suitable	for grease and high-viscosity grease
filling capacity	400 g (14.0 oz.) grease cartridge / 500 ccm (17.5 oz.) bulk grease

for central lubrication systems

- for fast filling of central lubrication systems with grease and high-viscosity grease
- suitable for bulk grease and for grease cartridges of 400 g

packed in	polybag or bulk
weight	960 g (33.9 oz.) + packaging
dimensions	64 x 460 mm (2.5" x 18.1")

Ref. No.:

5556010

ACCESSORIES FOR SUCTION GUNS

UMETA's high quality suction gun accessories let you handle any job easily!

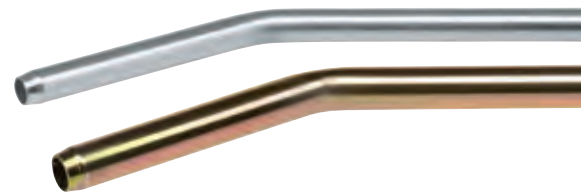

SDF

SDF 10



SDF 13



Type	Connection	Total length	Ref. No.:
SDF 10	M 10 x 1	300 mm (11.8")	7277113

transparent, flexible hose

· for decanting fluid contents

Type	Connection	Total length	Ref. No.:
SDF 13	M 13 x 1	300 mm (11.8")	7277313

SDK

SDK 10



SDK 13



Type	Connection	Total length	Ref. No.:
SDK 10	M 10 x 1	190 mm (7.5")	7265113

Nozzle tube

· bent

Type	Connection	Total length	Ref. No.:
SDK 13	M 13 x 1	250 mm (9.8")	7266313

SDG

SDG 10



SDG 13



Type	Connection	Total length	Ref. No.:
SDG 10	M 10 x 1	190 mm (7.5")	7255113

Nozzle tube

· straight

Type	Connection	Total length	Ref. No.:
SDG 13	M 13 x 1	250 mm (9.8")	7256313

OTHER GARAGE EQUIPMENT

UMETA TWIN-LOCK® Ultra Case Kit



The complete lubricating equipment in a handy carrying case, which contains everything you need for any application, especially our **UMETA TWIN-LOCK® Ultra Grease Gun 75/PKU according to DIN 1283**. The carrying case kit comes with the practical UMETA hose parking unit. The grease gun can be hung up by the provided wall bracket, and is thus always at hand.

UMETA TWIN-LOCK® Ultra Grease Gun 75/PKU

Top model, which combines quality, function and design.

- for 400 g (14.0 oz.) grease cartridge / 500 ccm (17.5 oz.) bulk grease
- ergonomic grips made of anti-slip material
- filler valve, DIN 1283 included
- with TWIN-LOCK system and EVER-FLOW system

Accessories kit, consisting of:

- high pressure hose 340/GLN
- nozzle tube 110/G
- hydraulic coupler 515/G-4
- quick-adapter, as short version 200/M 4, 200/M 1, 200/M 22, 200/S, 200/XS
- grease nipple assortment 60s, each 5 pcs. H1/H2/H3 6 x 1, 8 x 1, 10 x 1, R 1/8
- grease cartridge 400 g
- hose parking unit at hand lever
- wall bracket

Connection	Packaging	Scope of delivery	Ref. No.:
M 10 x 1	carrying case	complete accessories	6900096
G 1/8	carrying case	complete accessories	6900098

	Ref. No.:
case without content	6900095

Portable Lubrication System CARRY-LUBE



- hand- or foot operated high pressure equipment
- for 2.5 kg grease bucket (diameter 160 mm)
- adjustable for greasing with high volume or high pressure
- with high-pressure grease gun up to 690 bar / 10,000 PSI
- connected with 1.5 m hose
- capable for approx. 30 high pressure shots

suitable for length of suction tube output	grease up to NLGI 2 150 mm (5.9") max. 1.25 g (0.044 oz.) per shot (approximately 30 shots per loading)	packed in gross weight net weight dimensions (L x W x H)	single carton box 4,330 g 4,030 g 200 x 215 x 460 mm
operating pressure	max. 690 bar (10,000 PSI)		

Packaging	Ref. No.:
cardboard box	9626825



UMETA Filling Device for Grease Guns

All grease guns with a DIN filler valve can be filled from the bucket easily and safely by the inclined filling coupler. With variable screw-on features, the filling devices work with all common bucket sizes. The loose lid protects against dirt and grime and serves for simple control of filling height at the same time.

delivery capacity	30 ccm (1.1 oz.)/stroke	packed in weight	cardboard box
operating pressure	8 bar / 1.2 PSI		in kgs, incl. packaging

Content grease bucket	Grease Bucket Ø	Bucket height max. in mm (inches)	Weight in kgs	Dimensions (L x W x H) in mm	Ref. No.:
5 kg	180 – 210 mm	510 (20")	3.8	670 x 420 x 100	7591783
10 kg	210 – 240 mm	510 (20")	3.9	670 x 420 x 100	7591883
15 kg	240 – 270 mm	510 (20")	4.3	670 x 420 x 100	7591483
20 kg	270 – 310 mm	510 (20")	4.8	670 x 420 x 100	7591983
25 kg	310 – 335 mm	680 (26.8")	5.4	670 x 420 x 100	7591583
50 kg	335 – 385 mm	680 (26.8")	6.5	800 x 420 x 100	7591683



UMETA Handlever Oil Barrel Pump (steel tube)

- with telescopic tube and steel discharge elbow
- for 60/200/220 ltr. drums
- suitable for motor, hydraulic, and gear oil, diesel, petroleum, heating oil, waste oil

suitable for	motor, hydraulic, and gear oils up to SAE 50	total height	1,250 mm (49.2")
tube type	made of zinc-plated steel	total width	520 mm (20.5")
length/dip depth	440 – 860 mm (17.3" - 33.9")	net weight	1,800 g (63.5 oz.)
tube Ø	25 – 35 mm (1.0" x 1.4")	packed in	cardboard box
drum thread	2"	gross weight	1,900 g (67 oz.)
delivery capacity	16 ltr. (541 oz.)/min. 300 ccm (10.1 oz.)/stroke	dimensions (L x W x H)	460 x 140 x 70 mm (18.1 x 5.5 x 2.75")

Packaging	Ref. No.:
cardboard box	9626830



UMETA Rotary Oil Barrel Pump

- with steel tube and steel discharge elbow
- for 60/200/220 ltr. drums
- comes with: 1 m PVC hose with fold protection spring, 2 hose clamps

tube type	made of zinc-plated steel	total width	210 mm (8.3")
length/dip depth	980 mm (38.6")	net weight	4,800 g (169 oz.)
tube Ø	25 – 35 mm (1.0" x 1.4")	packed in	cardboard box
drum thread	2"	weight	4,900 g (173 oz.)
delivery capacity	35 ltr. (1,183 oz.)/min.	dimensions (L x W x H)	360 x 160 x 130 mm (14.2 x 6.3 x 5.1")
total height	1,250 mm (49.2")		

Packaging	Ref. No.:
cardboard box	9626820

UMETA Oil Cans *



Stand out for the following advantages:

- precision double-pumping system made of brass
- high pressure performance
- large filling hole
- red stove enamelling
- easy to disassemble, therefore, easy to clean
- enormously stable due to large bottom
- packed: 12 pcs. per size in cardboard box

Type	Nominal content	Connection	Net weight	Ref. No.:
K 200 flex	200 ml	flexible hose	195 g	7522224
K 300 flex	300 ml	flexible hose	215 g	7523224
K 500 flex	500 ml	flexible hose	235 g	7525224

Oil Measuring Cans *



- made of especially stable red/ecru polyamide
- available in different sizes

Please note our packing units!

Size	Packing unit	Ref. No.:
0.5 ltr.	15 pcs.	9626700
1.0 ltr.	15 pcs.	9626701
2.0 ltr.	10 pcs.	9626702
5.0 ltr.	4 pcs.	9626705



The flexible spout is available for all different can sizes and facilitates filling without additional funnel use.

Size	Packing unit	Ref. No.:
1.0, 2.0 + 3.0 ltr.	loose packaging	9626708

Measuring Cups *



- made of transparent polyamide
- available in different sizes
- embossed labelling

Please note our packing units!

Size	Packing unit	Ref. No.:
0.25 ltr.	25 pcs.	9626725
0.5 ltr.	16 pcs.	9626800
1.0 ltr.	12 pcs.	9626801
2.0 ltr.	12 pcs.	9626802
3.0 ltr.	10 pcs.	9626803
5.0 ltr.	5 pcs.	9626805

* We reserve to modify colour and form.

Funnels *

Funnels made of especially stable red polyamide, available in different sizes and kits. The funnels are available both with and without filter screen, partially equipped with flexible plastics or brass hose, or a bent plastics tube, respectively.

Please note our packing units!

Type	Size (in mm)	Packing unit	Ref. No.:
kit of 4	Ø 60/80/100/120	10 pcs.	9626103
one size	Ø 100	12 pcs.	9626109
one size	Ø 140	12 pcs.	9626140

Type	Size (in mm)	Packing unit	Ref. No.:
with filter and flex hose, polyamide	Ø 210	12 pcs.	9626396

Other versions upon request.

Washing tub, 6.0 ltr. *

· made of especially stable red polyamide

Packing unit	Ref. No.:
6 pcs.	9626810

UMETA grease cartridges according to DIN 1284 *

filling quantity	400 g/14.0 oz.
thaw point	180 °C/356 °F
NLGI class	2
packing unit	24 pcs.

Packing unit	Ref. No.:
24 pcs.	7371953

Super lithium multipurpose grease

- cartridge according to DIN 1284
- suitable for lubricating normally strained bearings
- suitable for all grease guns according to DIN 1283
- universally applicable

application temperature	-30 °C/ -22 °F
upon permanent operation	up to +120 °C/ 248 °F
temporarily	up to +130 °C/266 °F

* We reserve to modify colour and form.

INJECTION GUNS

UMETA Hand lever injection guns for sealing and pressing works, specially well for building reconstruction. Viton-sealings allow for cleaning with solvents and for multi-use. The different tube lengths make the filling volume up to 1,100 ccm (35.0 oz.) possible.



75/PKI Zinc



barrel version	made of zinc-plated steel Ø 56 mm (2.2")
barrel length suitable	295 mm for resin
filling capacity	550 ccm (17.5 Oz.) bulk grease
connection thread	M 10 x 1 or G 1/8 upon request 1/8 NPT

Injection gun

- for 550 ccm (17.5 oz.) filling material
- with rolled, zinc-plated steel cap

operating pressure	400 bar / 5,800 PSI
output	approx. 1.9 ccm (0.06 oz.)/stroke
testing pressure	800 bar / 11,600 PSI
packed in	polybag
weight	960 g (33.9 oz.) + accessories and packaging
dimensions (L x W x H)	356 x 125 x 67.5 mm (14.0 x 4.9 x 2.6")

Connection	Packed in	Scope of delivery	Ref. No.:
M 10 x 1	polybag	without accessories	7091156

Connection	Packed in	Scope of delivery	Ref. No.:
G 1/8	polybag	without accessories	7091157

75/PKI Zinc



barrel version made of zinc-plated steel
 Ø 56 mm (2.2")
 barrel length 296 mm
 suitable for resin
 filling capacity 550 ccm (17.5 Oz.) bulk grease
 connection thread M 10 x 1 or G 1/8, upon request 1/8 NPT

Connection	Packed in	Scope of delivery	Ref. No.:
M 10 x 1	polybag	without accessories	V000334

Injection gun

- für 550 ccm (17.5 oz.) filling material
- with orange polyamide cap

operating pressure 400 bar / 5,800 PSI
 output approx. 1.9 ccm (0.06 Oz.)/stroke
 testing pressure 800 bar / 11,600 PSI
 packed in polybag
 weight 960 g (33.9 oz.) + accessories and packaging
 dimensions (L x W x H) 356 x 125 x 67.5 mm (14.0 x 4.9 x 2.6")

Connection	Packed in	Scope of delivery	Ref. No.:
G 1/8	polybag	without accessories	V001440

75/LLI Zinc



barrel version made of zinc-plated steel
 Ø 56 mm (2.2")
 barrel length 485 mm
 suitable for resin
 filling capacity 1,100 ccm (35 oz.) bulk material
 connection thread M 10 x 1 or G 1/8, upon request 1/8 NPT

Connection	Packed in	Scope of delivery	Ref. No.:
M 10 x 1	polybag	without accessories	V000340

Injection gun

- long version for 1,100 ccm (35 oz.) filling material
- with orange polyamide cap

operating pressure 400 bar / 5,800 PSI
 output approx. 1.9 ccm (0.06 Oz.)/stroke
 testing pressure 800 bar / 11,600 PSI
 packed in polybag
 weight 1,230 g (43.4 oz.) + accessories and packaging
 dimensions (L x W x H) 545 x 125 x 67.5 mm (21.5 x 4.9 x 2.6")

Connection	Packed in	Scope of delivery	Ref. No.:
G 1/8	polybag	without accessories	V001478

75/LLI Zinc



barrel version made of zinc-plated steel
 Ø 56 mm (2.2")
 barrel length 453 mm
 suitable for resin
 filling capacity 1,000 ccm (32 oz.) bulk grease
 connection thread M 10 x 1 or G 1/8, upon request 1/8 NPT

Connection	Packed in	Scope of delivery	Ref. No.:
M 10 x 1	polybag	without accessories	7091312

Injection gun

- long version for 1,000 ccm (32 oz.) filling material
- with zinc-plated steel screw cap

operating pressure 400 bar / 5,800 PSI
 output approx. 1.9 ccm (0.06 Oz.)/stroke
 testing pressure 800 bar / 11,600 PSI
 packed in polybag
 weight 1,260 g (44.4 oz.) + accessories and packaging
 dimensions (L x W x H) 513 x 125 x 67.5 mm (20.2 x 4.9 x 2.6")

Connection	Packed in	Scope of delivery	Ref. No.:
G 1/8	polybag	without accessories	upon request

GREASE NIPPLES

Maintaining permanent motion!

They are small and inconspicuous, but responsible for keeping machines and all kinds of equipment in motion - whether in a harvester in Russia, a pipeline in Alaska, or a brewery in Australia. There is a UMETA Grease Nipple for every application purpose in most sizes, types and composition. With a range of more than 1,500 different types of nipples with about 70 different thread forms, we offer the largest product line worldwide.

Depending on the application and the installation sites, we can manufacture grease nipple according to international standards. Other than a standard version made of steel, zinc-plated and passivated, we offer many other types, made of brass or stainless steel. You will always find a solution in our range of products - even for the most challenging application. Rely on us - since we are manufacturer and not a dealer - for about 80 years!

UMETA GREASE NIPPLES - ADVANTAGES AT A GLANCE

- 1,500 available types
- hydraulic-type-, ball-type-, flush-type-, bayonet-, and button-head nipples
- standard versions made of zinc-plated steel, stainless steel, or brass
- case-hardened according to DIN
- international product standards (e. g. DIN, ISO, SAE, BS, JIS)
- individual, custom-designed solutions
- individual packaging according to customers requirements

FUNCTION OF A GREASE NIPPLE

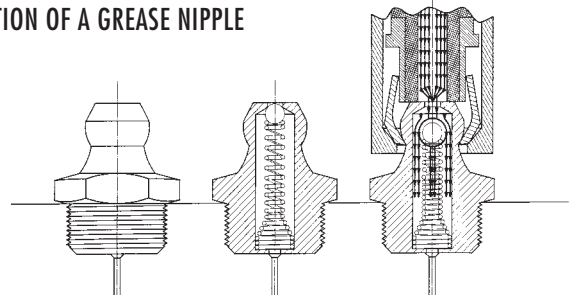

TASKS OF A GREASE NIPPLE

- protection of the lubrication point against dirt and humidity – no sealing against internal pressure
- standardized connection to the grease gun
- essential for maintenance and repairs

RANGE OF APPLICATIONS

- bearings
- hinges for machines, vehicles, industry
- cardan shafts
- drive shafts
- linear guides
- hydraulic cylinders
- drives
- chains
- axels

GREASE NIPPLES ARE MANUFACTURED OF

- steel: 1.0718 (11SMnPb30+C) SAE 12L13
- stainless steel: 1.4305 ~ ASTM303 (SST303); 1.4401, 1.4404 ~ ASTM316, 316L (SST316L)
- brass: CuZn39 Pb3 (CW614N)

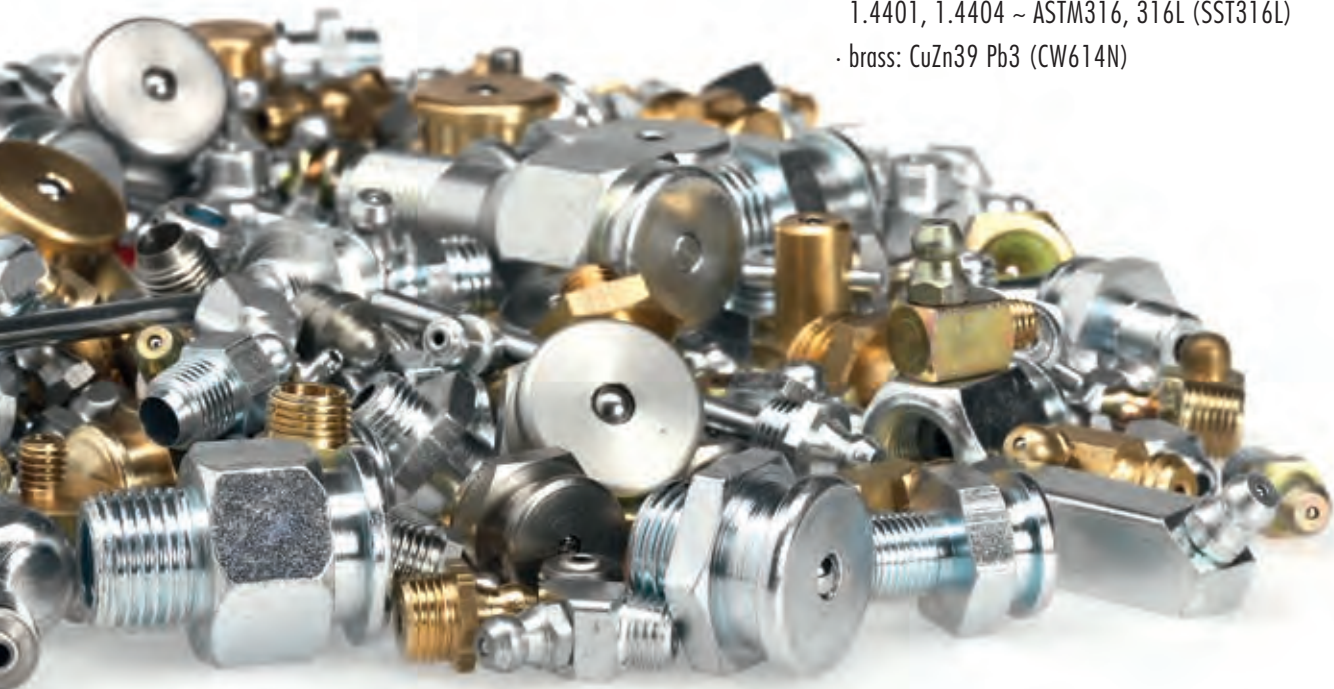

UMETA HYDRAULIC-TYPE GREASE NIPPLES ACCORDING TO DIN 71412

APPLICATION AREA

UMETA hydraulic-type nipples are suitable for all standard lubrication points, which have to be frequently lubricated in a reliable way. Due to their multi-purpose field of application, they are the most commonly used types of grease nipples.

VERSIONS

In general, our hydraulic-type grease nipples according to DIN are made of steel, case-hardened, zinc-plated and passivated, and they are featured with a tapered thread. The head diameter is 6.5 (-0.2) mm / 0.256" (- 0.008"). For safety reasons and in order to avoid abrasion wear, the standard demands 550 HV as a minimum for a surface hardness. Therefore, we operate this decisive process in our own curing oven. We offer various standard types also in brass or stainless steel 1.4305 ~ ASTM 303 and 1.4404 ~ ASTM 316L (V2A/V4A). Of course, our hydraulic-type nipples are also available in different angle versions, with a self-forming thread, or as drive-in type.

SPECIAL VERSIONS

Upon request, UMETA manufactures hydraulic-type nipples in other versions, with respect to the following:

- dimension
- material
- thread size
- thread form (e. g. with cylindrical thread)
- opening pressure
- surface colour (e. g. yellow passivated)
- further surface treatment
- unhardened
- etc.

MOUNTING INSTRUCTIONS

In order to allow for a proper lubrication with all common grease guns, the head space, which is necessary for installation, should be considered (please see table with dimensions).

OPERATING INSTRUCTIONS

As suitable lubricating nozzle, we recommend our hydraulic couplers.

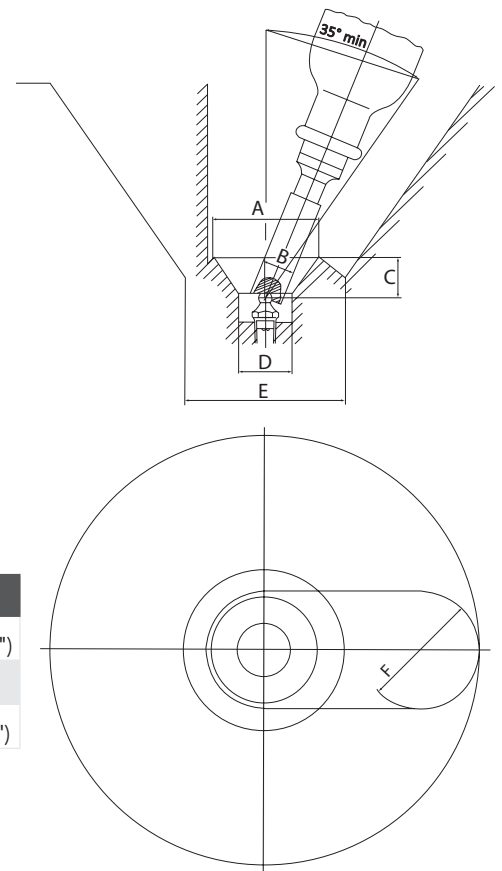

Head space	
A = 50 mm (1.97")	D = 25 mm (0.98" - ⁶³ / ₆₄ ")
B = 16.5 mm (0.65")	E = 75 mm (3")
C = 19 mm (0,75" - ³ / ₄ ")	F = 55 mm (2.16" - 2 ¹ / ₈ ")



Type H1



Hydraulic-Type Grease Nipples

- according to DIN 71412
- straight version A/180°
- standard versions according to DIN are made of steel, case-hardened, zinc-plated and passivated
- for other types and materials, please see table, or upon request

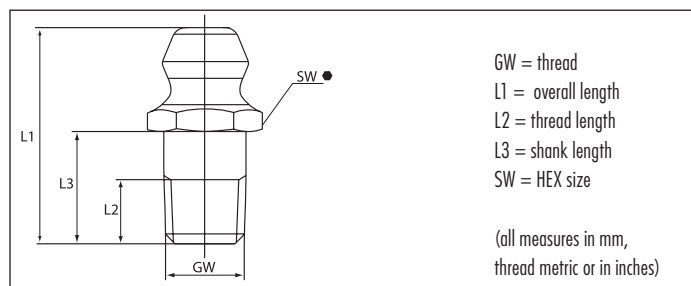

GW M 5 x 0.8				Ref.- No.:			
L1	L2	L3	SW	Steel	Brass	SST303	SST316L
15	5.5		7mm HEX ●	1100701	1110701	1120701	

GW M 6 x 0.75				Ref.- No.:			
L1	L2	L3	SW	Steel	Brass	SST303	SST316L
15	5.5		7mm HEX ●	1100703	1110703	1120703	
24	6	14	7mm HEX ●	5241056			
29	8.3	19	7mm HEX ●	5241059			

GW M 6 x 1.0				Ref.- No.:			
L1	L2	L3	SW	Steel	Brass	SST303	SST316L
13.5	4		7mm HEX ●	5241007	5241101	5241102	
15	5.5		7mm HEX ●	1100704	1110704	1120704	1140704
17.3	5.6	8.5	7mm HEX ●	5241038			
24	6	14	7mm HEX ●	5241057			
29	8.3	19	7mm HEX ●	*5241060			
41	6	31	7mm HEX ●	5313742			
15	5.5		11mm HEX ●	1101104		1121104	

GW M 7 x 1.0				Ref.- No.:			
L1	L2	L3	SW	Steel	Brass	SST303	SST316L
15	5.5		9mm HEX ●	1100905			

GW M 8 x 0.75				Ref.- No.:			
L1	L2	L3	SW	Steel	Brass	SST303	SST316L
15	5.5		9mm HEX ●	1100906			

GW M 8 x 1.0				Ref.- No.:			
L1	L2	L3	SW	Steel	Brass	SST303	SST316L
15	5.5		9mm HEX ●	1100907	1110907	1120907	1140907
18.5	8.5		9mm HEX ●	5241009			

GW M 8 x 1.25				Ref.- No.:			
L1	L2	L3	SW	Steel	Brass	SST303	SST316L
15	5.5		9mm HEX ●	1100908	1110908	1120908	1140908

GW M 10 x 1.0				Ref.- No.:			
L1	L2	L3	SW	Steel	Brass	SST303	SST316L
15	5.5		11mm HEX ●	1101109	1111109	1121109	1141109
17.5	7.5		11mm HEX ●	5241074			

GW M 10 x 1.25				Ref.- No.:			
L1	L2	L3	SW	Steel	Brass	SST303	SST316L
15	5.5		11mm HEX ●	1101110			

GW M 10 x 1.5				Ref.- No.:			
L1	L2	L3	SW	Steel	Brass	SST303	SST316L
15	5.5		11mm HEX ●	1101111	1111111	1121111	1141111

GW M 12 x 1.0				Ref.- No.:			
L1	L2	L3	SW	Steel	Brass	SST303	SST316L
17.5	6.5		14mm HEX ●	1101412			

GW M 12 x 1.25				Ref.- No.:			
L1	L2	L3	SW	Steel	Brass	SST303	SST316L
17.5	6.5		14mm HEX ●	1101413			

GW M 12 x 1.5				Ref.- No.:			
L1	L2	L3	SW	Steel	Brass	SST303	SST316L
17.5	6.5		14mm HEX ●	1101414	1111414	1121414	

GW M 12 x 1.75				Ref.- No.:			
L1	L2	L3	SW	Steel	Brass	SST303	SST316L
17.5	6.5		14mm HEX ●	1101415		1121415	

GW M 14 x 1.5				Ref.- No.:			
L1	L2	L3	SW	Steel	Brass	SST303	SST316L
17.5	6.5		14mm HEX ●	1101417			

GW M 14 x 2.0				Ref.- No.:			
L1	L2	L3	SW	Steel	Brass	SST303	SST316L
17.5	6.5		14mm HEX ●	1101418			

GW M 16 x 1.5				Ref.- No.:			
L1	L2	L3	SW	Steel	Brass	SST303	SST316L
18	7		17mm HEX ●	1101719			

*unhardened

GW R 1/8, 1/8 - 28 BSP								Ref.- No.:	
L1	L2	L3	SW	Steel	Brass	SST303	SST316L		
43	6	33**	9mm HEX ●	5241070					
15	5.5		11mm HEX ●	1101156	1111156	1121156	1141156		

GW R 1/4, 1/4 - 19 BSP								Ref.- No.:	
L1	L2	L3	SW	Steel	Brass	SST303	SST316L		
17.5	6.5		14mm HEX ●	1101457	1111457	1121457	1141457		
19	8		14mm HEX ●	5241071					

GW R 3/8, 3/8 - 19 BSP								Ref.- No.:	
L1	L2	L3	SW	Steel	Brass	SST303	SST316L		
18	7		17mm HEX ●	1101758		1121758			

GW 1/8" - 27 NPT/PTF								Ref.- No.:	
L1	L2	L3	SW	Steel	Brass	SST303	SST316L		
45	6.5	35**	9mm HEX ●	5241076					
65	8	55**	9mm HEX ●	5241077					
15	5.5		11mm HEX ●	1101167	1111167				
17	6.5		11mm HEX ●				1141167		
17.5	6.5	7.5	11mm HEX ●	5241024	5241105	5241106			
31	6	21	11mm HEX ●	5241075					

GW 1/4" - 18 NPT/PTF								Ref.- No.:	
L1	L2	L3	SW	Steel	Brass	SST303	SST316L		
17.5	6.5		14mm HEX ●	1101468					
19	8		14mm HEX ●	5241072					
21	9		14mm HEX ●				1141468		

GW 1/4" - 28 NF/UNF/SAE								Ref.- No.:	
L1	L2	L3	SW	Steel	Brass	SST303	SST316L		
13.5	4		7mm HEX ●	5241054	5241103				
15	5.5		7mm HEX ●	1100737	1110737	1120737			
17.3	5.6	8.5	7mm HEX ●	5241055					
24	6	14	7mm HEX ●	5241058					
29	8.3	19	7mm HEX ●	5241061					
41	6	31	7mm HEX ●	5241080					

GW 1/4" - 26 BSF								Ref.- No.:	
L1	L2	L3	SW	Steel	Brass	SST303	SST316L		
15	5.5		7mm HEX ●	1100744	1110744	1120744			
29	8.3	19	7mm HEX ●	5241062					

GW 1/4" BSW								Ref.- No.:	
L1	L2	L3	SW	Steel	Brass	SST303	SST316L		
15	5.5		7mm HEX ●	1100750					

GW 5/16" - 24 NF/UNF/SAE								Ref.- No.:	
L1	L2	L3	SW	Steel	Brass	SST303	SST316L		
14	4		9mm HEX ●	5241068					
15	5.5		9mm HEX ●	1100938	1110938	1120938			

GW 5/16" - 22 BSF								Ref.- No.:	
L1	L2	L3	SW	Steel	Brass	SST303	SST316L		
15	5.5		9mm HEX ●	1100945					

GW 5/16" BSW								Ref.- No.:	
L1	L2	L3	SW	Steel	Brass	SST303	SST316L		
15	5.5		9mm HEX ●	1100951					

GW 3/8" - 18 NPT/PTF								Ref.- No.:	
L1	L2	L3	SW	Steel	Brass	SST303	SST316L		
18	7		17mm HEX ●	1101769					

GW 3/8" - 20 BSF								Ref.- No.:	
L1	L2	L3	SW	Steel	Brass	SST303	SST316L		
15	5.5		11mm HEX ●	1101146					

GW 3/8" - 24 NF/UNF/SAE								Ref.- No.:	
L1	L2	L3	SW	Steel	Brass	SST303	SST316L		
15	5.5		11mm HEX ●	1101139	1111139	1121139			

GW 3/8" BSW								Ref.- No.:	
L1	L2	L3	SW	Steel	Brass	SST303	SST316L		
15	5.5		11mm HEX ●	1101152					

GW 1/2" - 20 UNF/NF/SAE								Ref.- No.:	
L1	L2	L3	SW	Steel	Brass	SST303	SST316L		
17.5	6.5		14mm HEX ●	1101440					

** 2-parts

Type H2



Hydraulic-Type Grease Nipples

- according to DIN 71412
- angled version B/45° /67°
- optionally available with square or hexagonal body
- standard versions according to DIN are made of steel, zinc-plated and passivated, head case-hardened
- with tapered thread
- for other types and materials, please see table, or upon request

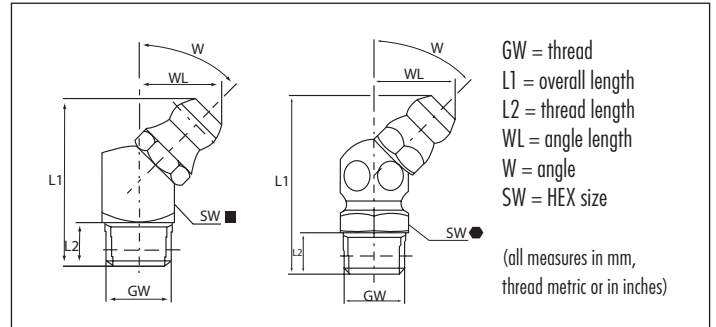

GW M 5 x 0.8						Ref.- No.:			
L1	L2	WL	W	SW		Steel	Brass	SST303	SST316L
23.5	5.5	10.5	45°	9mm HEX	●	1200901			

GW M 6 x 0.75						Ref.- No.:			
L1	L2	WL	W	SW		Steel	Brass	SST303	SST316L
20.5	5.5	10.5	45°	9mm SQ.	■	1204503			
23.5	5.5	10.5	45°	9mm HEX	●	1200903			

GW M 6 x 1.0						Ref.- No.:			
L1	L2	WL	W	SW		Steel	Brass	SST303	SST316L
20.5	5.5	10.5	45°	9mm SQ.	■	1204504			
23.5	5.5	10.5	45°	9mm HEX	●	1200904	1210904	1220904	1240904
17.5	5.5	12.3	67°	9mm SQ.	■	1404504			
20.5	5.5	12.2	67°	9mm HEX	●	1400904			

GW M 7 x 1.0						Ref.- No.:			
L1	L2	WL	W	SW		Steel	Brass	SST303	SST316L
23.5	5.5	10.5	45°	9mm HEX	●	1200905			

GW M 8 x 0.75						Ref.- No.:			
L1	L2	WL	W	SW		Steel	Brass	SST303	SST316L
23.5	5.5	10.5	45°	9mm HEX	●	1200906			

GW M 8 x 1.0						Ref.- No.:			
L1	L2	WL	W	SW		Steel	Brass	SST303	SST316L
20.5	5.5	10.5	45°	9mm SQ.	■	1204507			
23.5	5.5	10.5	45°	9mm HEX	●	1200907	1210907	1220907	1240907
17.5	5.5	12.3	67°	9mm SQ.	■	1404507			
20.5	5.5	12.2	67°	9mm HEX	●	1400907			

GW M 8 x 1.25						Ref.- No.:			
L1	L2	WL	W	SW		Steel	Brass	SST303	SST316L
20.5	5.5	10.5	45°	9mm SQ.	■	1204508			
23.5	5.5	10.5	45°	9mm HEX	●	1200908	1210908	1220908	
20.5	5.5	12.2	67°	9mm HEX	●	1400908			

GW M 10 x 1.0						Ref.- No.:			
L1	L2	WL	W	SW		Steel	Brass	SST303	SST316L
20.5	5.5	11	45°	11mm SQ.	■	1204709			
25	5.5	11.5	45°	11mm HEX	●	1201109	1211109	1221109	1241109
26	7	11.5	45°	11mm HEX	●	5242085			
47	7	11	45°	11mm SQ.	■	5242088			
25	5.5	11.5	67°	11mm HEX	●	1401109			

GW M 10 x 1.25						Ref.- No.:			
L1	L2	WL	W	SW		Steel	Brass	SST303	SST316L
25	5.5	11.5	45°	11mm HEX	●	1201110			

GW M 10 x 1.5						Ref.- No.:			
L1	L2	WL	W	SW		Steel	Brass	SST303	SST316L
25	5.5	11.5	45°	11mm HEX	●	1201111		1221111	

GW M 12 x 1.0						Ref.- No.:			
L1	L2	WL	W	SW		Steel	Brass	SST303	SST316L
22.5	6.5	12	45°	14mm HEX	●	1201412			

GW M 12 x 1.5						Ref.- No.:			
L1	L2	WL	W	SW		Steel	Brass	SST303	SST316L
22.5	6.5	12	45°	14mm HEX	●	1201414			

GW M 12 x 1.75						Ref.- No.:			
L1	L2	WL	W	SW		Steel	Brass	SST303	SST316L
22.5	6.5	12	45°	14mm HEX	●	1201415			

GW M 14 x 1.5						Ref.- No.:			
L1	L2	WL	W	SW		Steel	Brass	SST303	SST316L
22.5	6.5	12	45°	14mm HEX	●	1201417			

GW M 16 x 1.5						Ref.- No.:			
L1	L2	WL	W	SW		Steel	Brass	SST303	SST316L
25.5	7	13.5	45°	17mm HEX	●	1201719			

GW R 1/8, 1/8 - 28 BSP						Ref.- No.:			
L1	L2	WL	W	SW		Steel	Brass	SST303	SST316L
20.5	5.5	11	45°	11mm SQ. ■		1204756			
25	5.5	11.5	45°	11mm HEX ●		1201156	1211156	1221156	1241156
28.5	9	11.5	45°	11mm HEX ●		5241236			
36	5.5	11	45°	11mm SQ. ■		5242087			
25	5.5	11.5	67°	11mm HEX ●		1401156			

GW R 1/4, 1/4 - 19 BSP						Ref.- No.:			
L1	L2	WL	W	SW		Steel	Brass	SST303	SST316L
22.5	6.5	12	45°	14mm HEX ●		1201457	1211457	1221457	1241457

GW R 3/8, 3/8 - 19 BSP						Ref.- No.:			
L1	L2	WL	W	SW		Steel	Brass	SST303	SST316L
25.5	7	13.5	45°	17mm HEX ●		1201758			

GW 1/8" - 27 NPT/PTF						Ref.- No.:			
L1	L2	WL	W	SW		Steel	Brass	SST303	SST316L
20.5	5.5	11	45°	11mm SQ. ■		1204767			
27	7	11.5	45°	11mm HEX ●		5242104			
24	7	14	67°	11mm HEX ●		5242105			

GW 1/4" - 18 NPT/PTF						Ref.- No.:			
L1	L2	WL	W	SW		Steel	Brass	SST303	SST316L
22.5	6.5	12	45°	14mm HEX ●		1201468			

GW 1/4" - 26 BSF						Ref.- No.:			
L1	L2	WL	W	SW		Steel	Brass	SST303	SST316L
23.5	5.5	10.5	45°	9mm HEX ●		1200944		1220944	
20.5	5.5	12.2	67°	9mm HEX ●		1400944			

GW 1/4" - 28 NF/UNF/SAE						Ref.- No.:			
L1	L2	WL	W	SW		Steel	Brass	SST303	SST316L
23.5	5.5	10.5	45°	9mm HEX ●		1200937	1210937	1220937	
20.5	5.5	12.2	67°	9mm HEX ●		1400937			

GW 1/4" - BSW						Ref.- No.:			
L1	L2	WL	W	SW		Steel	Brass	SST303	SST316L
23.5	5.5	10.5	45°	9mm HEX ●		1200950			

GW 5/16" - 22 BSF						Ref.- No.:			
L1	L2	WL	W	SW		Steel	Brass	SST303	SST316L
23.5	5.5	10.5	45°	9mm HEX ●		1200945			
20.5	5.5	12.2	67°	9mm HEX ●		1400945			

GW 5/16" - 24 NF/UNF/SAE						Ref.- No.:			
L1	L2	WL	W	SW		Steel	Brass	SST303	SST316L
23.5	5.5	10.5	45°	9mm HEX ●		1200938	1210938	1220938	
20.5	5.5	12.2	67°	9mm HEX ●		1400938			

GW 5/16" - BSW						Ref.- No.:			
L1	L2	WL	W	SW		Steel	Brass	SST303	SST316L
23.5	5.5	10.5	45°	9mm HEX ●		1200951			

GW 3/8" - NPT/PTF						Ref.- No.:			
L1	L2	WL	W	SW		Steel	Brass	SST303	SST316L
25.5	7	13.5	45°	17mm HEX ●		1201769			

GW 3/8" - 20 BSF						Ref.- No.:			
L1	L2	WL	W	SW		Steel	Brass	SST303	SST316L
25	5.5	11.5	45°	11mm HEX ●		1201146			
25	5.5	11.5	67°	11mm HEX ●		1401140			

GW 3/8" - 24 NF/UNF/SAE						Ref.- No.:			
L1	L2	WL	W	SW		Steel	Brass	SST303	SST316L
25	5.5	11.5	45°	11mm HEX ●		1201139			
25	5.5	11.5	67°	11mm HEX ●		1401139			

GW 3/8" BSW						Ref.- No.:			
L1	L2	WL	W	SW		Steel	Brass	SST303	SST316L
25	5.5	11.5	45°	11mm HEX ●		1201152			

GW 1/2" - 20 UNF/NF/SAE						Ref.- No.:			
L1	L2	WL	W	SW		Steel	Brass	SST303	SST316L
22.5	6.5	12	45°	14mm HEX ●		1201440			

Type H3



Hydraulic-Type Grease Nipples

- according to DIN 71412
- angled version C/90°
- standard versions according to DIN are made of steel, zinc-plated and passivated, head case-hardened
- with tapered thread
- for other types and materials, please see table, or upon request

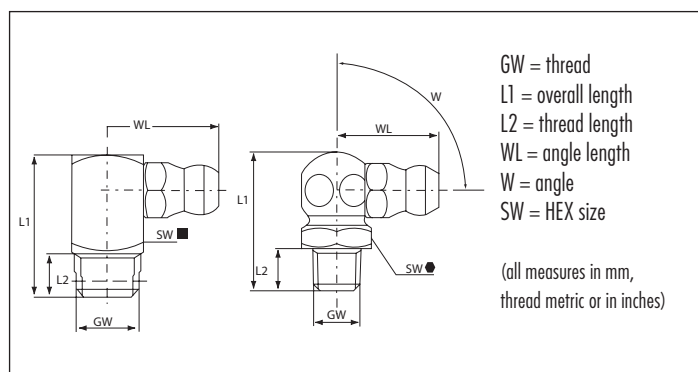

GW M 5 x 0.8						Ref.- No.:			
L1	L2	WL	W	SW		Steel	Brass	SST303	SST316L
18	5.5	13	90°	9mm HEX	■	1300901			

GW M 6 x 0.75						Ref.- No.:			
L1	L2	WL	W	SW		Steel	Brass	SST303	SST316L
18	5.5	14	90°	9mm SQ.	■	1304503			
18	5.5	13	90°	9mm HEX	●	1300903			

GW M 6 x 1.0						Ref.- No.:			
L1	L2	WL	W	SW		Steel	Brass	SST303	SST316L
18	5.5	14	90°	9mm SQ.	■	1304504			
18	5.5	13	90°	9mm HEX	●	1300904	1310904	1320904	1341630

GW M 7 x 1.0						Ref.- No.:			
L1	L2	WL	W	SW		Steel	Brass	SST303	SST316L
18	5.5	13	90°	9mm HEX	●	1300905			

GW M 8 x 0.75						Ref.- No.:			
L1	L2	WL	W	SW		Steel	Brass	SST303	SST316L
18	5.5	13	90°	9mm HEX	●	1300906			

GW M 8 x 1.0						Ref.- No.:			
L1	L2	WL	W	SW		Steel	Brass	SST303	SST316L
18	5.5	13	90°	9mm HEX	●	1300907	1310907	1320907	1340907
18	5.5	14	90°	9mm SQ.	■	1304507			

GW M 8 x 1.25						Ref.- No.:			
L1	L2	WL	W	SW		Steel	Brass	SST303	SST316L
18	5.5	14	90°	9mm SQ.	■	1304508			
18	5.5	13	90°	9mm HEX	●	1300908	1310908	1320908	

GW M 10 x 1.0						Ref.- No.:			
L1	L2	WL	W	SW		Steel	Brass	SST303	SST316L
18	5.5	15	90°	11mm SQ.	■	1304709			
20	5.5	14	90°	11mm HEX	●	1301109	1311109	1321109	1341109
42	7	15	90°	11mm SQ.	■	5242092			

GW M 10 x 1.25						Ref.- No.:			
L1	L2	WL	W	SW		Steel	Brass	SST303	SST316L
20	5.5	14	90°	11mm HEX	●	1301110			

GW M 10 x 1.5						Ref.- No.:			
L1	L2	WL	W	SW		Steel	Brass	SST303	SST316L
20	5.5	14	90°	11mm HEX	●	1301111		1321111	

GW M 12 x 1.0						Ref.- No.:			
L1	L2	WL	W	SW		Steel	Brass	SST303	SST316L
22	6.5	14	90°	14mm HEX	●	1301412			

GW M 12 x 1.5						Ref.- No.:			
L1	L2	WL	W	SW		Steel	Brass	SST303	SST316L
22	6.5	14	90°	14mm HEX	●	1301414			

GW M 12 x 1.75						Ref.- No.:			
L1	L2	WL	W	SW		Steel	Brass	SST303	SST316L
22	6.5	14	90°	14mm HEX	●	1301415			1341415

GW M 14 x 1.5						Ref.- No.:			
L1	L2	WL	W	SW		Steel	Brass	SST303	SST316L
22	6.5	14	90°	14mm HEX	●	1301417			

GW M 14 x 2.0						Ref.- No.:			
L1	L2	WL	W	SW		Steel	Brass	SST303	SST316L
22	6.5	14	90°	14mm HEX	●	1301419			

GW R 1/8, 1/8 - 28 BSP						Ref.- No.:			
L1	L2	WL	W	SW		Steel	Brass	SST303	SST316L
18	5.5	15	90°	11mm SQ. ■		1304756			
20	5.5	14	90°	11mm HEX ●		1301156	1311156	1321156	1341156
42	7	15	90°	11mm SQ. ■		5242093			

GW R 1/4, 1/4 - 19 BSP						Ref.- No.:			
L1	L2	WL	W	SW		Steel	Brass	SST303	SST316L
22	6.5	14	90°	14mm HEX ●		1301457	1311457	1321457	1341457

GW R 3/8, 3/8 - 19 BSP						Ref.- No.:			
L1	L2	WL	W	SW		Steel	Brass	SST303	SST316L
20	7	19	90°	17mm HEX ●		1301758			

GW 1/8" - 27 NPT/PTF						Ref.- No.:			
L1	L2	WL	W	SW		Steel	Brass	SST303	SST316L
18	5.5	15	90°	11mm SQ. ■		1304767			

GW 1/4" - 18 NPT/PTF						Ref.- No.:			
L1	L2	WL	W	SW		Steel	Brass	SST303	SST316L
22	6.5	14	90°	14mm HEX ●		1301468			

GW 1/4" - 26 BSF						Ref.- No.:			
L1	L2	WL	W	SW		Steel	Brass	SST303	SST316L
18	5.5	13	90°	9mm HEX ●		1300944	1310944	1320944	

GW 1/4" - 28 NF/UNF/SAE						Ref.- No.:			
L1	L2	WL	W	SW		Steel	Brass	SST303	SST316L
18	5.5	13	90°	9mm HEX ●		1300937	1310937	1320937	

GW 1/4" BSW						Ref.- No.:			
L1	L2	WL	W	SW		Steel	Brass	SST303	SST316L
18	5.5	13	90°	9mm HEX ●		1300950		1320945	

GW 5/16" - 22 BSF						Ref.- No.:			
L1	L2	WL	W	SW		Steel	Brass	SST303	SST316L
18	5.5	13	90°	9mm HEX ●		1300945			

GW 5/16" - 24 NF/UNF/SAE						Ref.- No.:			
L1	L2	WL	W	SW		Steel	Brass	SST303	SST316L
18	5.5	13	90°	9mm HEX ●		1300938			

GW 5/16" BSW						Ref.- No.:			
L1	L2	WL	W	SW		Steel	Brass	SST303	SST316L
18	5.5	13	90°	9mm HEX ●		1300951			

GW 3/8" - 18 NPT/PTF						Ref.- No.:			
L1	L2	WL	W	SW		Steel	Brass	SST303	SST316L
20	7	19	90°	17mm HEX ●		1301760			

GW 3/8" - 20 BSF						Ref.- No.:			
L1	L2	WL	W	SW		Steel	Brass	SST303	SST316L
20	5.5	14	90°	11mm HEX ●		1301146			

GW 3/8" - 24 NF/UNF/SAE						Ref.- No.:			
L1	L2	WL	W	SW		Steel	Brass	SST303	SST316L
20	5.5	14	90°	11mm HEX ●		1301139			

GW 3/8" BSW						Ref.- No.:			
L1	L2	WL	W	SW		Steel	Brass	SST303	SST316L
20	5.5	14	90°	11mm HEX ●		1301152			

GW 1/2" - 20 UNF/UNF/SAE						Ref.- No.:			
L1	L2	WL	W	SW		Steel	Brass	SST303	SST316L
22	6.5	14	90°	14mm HEX ●		1301440			

UMETA HYDRAULIC GREASE NIPPLES WITH SELF-FORMING THREAD

APPLICATION AREA

By using UMETA grease nipples with self-forming thread (SFT / SFG) you effectively save the thread-cutting process in the borehole.

VERSIONS

For safety reasons and in order to avoid abrasion wear, the DIN standard for grease nipple with self-forming thread demands a specific surface hardness of 650 HV minimum as well as a particularly wide flank angle of 105° at the thread. For a better visual distinction, UMETA self-forming grease nipples are yellow passivated. Upon request, they are also available in another surface colour, e.g. blue passivated = silver coloured.

MOUNTING INSTRUCTIONS

The special thread angle and the specific hardness level allow these grease nipples to be driven and screwed into holes without prior thread cutting. Thus, the thread of the grease nipple forms its counter thread. Later, the grease nipple can easily be screwed out and be replaced by a standard grease nipple. The exact size of the core hole depends on the material and must be determined by mounting tests. The consistency of the receiving material is decisive. The standard gauge for the installation bore diameter of 0.4-0.5 mm (0.02") below nominal width have proved in daily use.

OPERATING INSTRUCTIONS

As suitable lubricating nozzle, we recommend our hydraulic couplers.

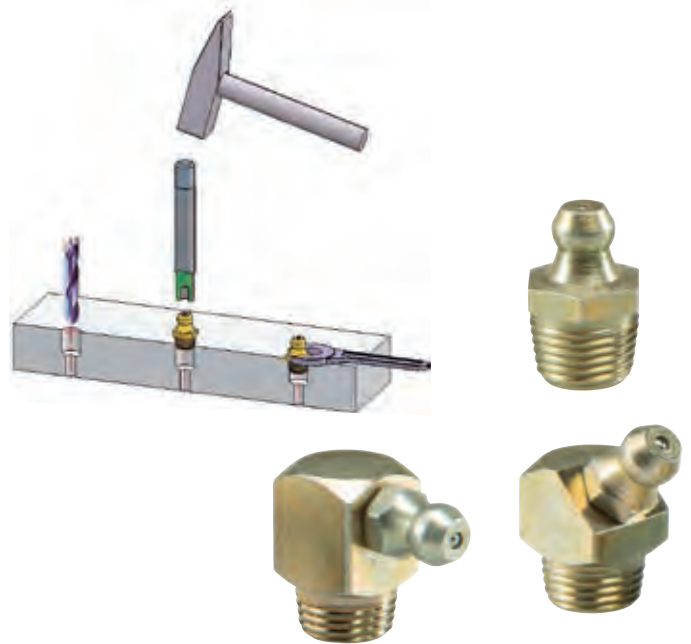
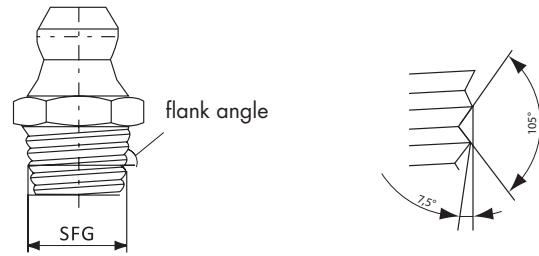

Type H1/S

Hydraulic-Type Grease Nipples with Self-Forming Thread



- according to DIN 71412
- straight version A/180°
- with self-forming thread, tapered
- standard version made of steel, case-hardened according to DIN (650HV) and yellow passivated

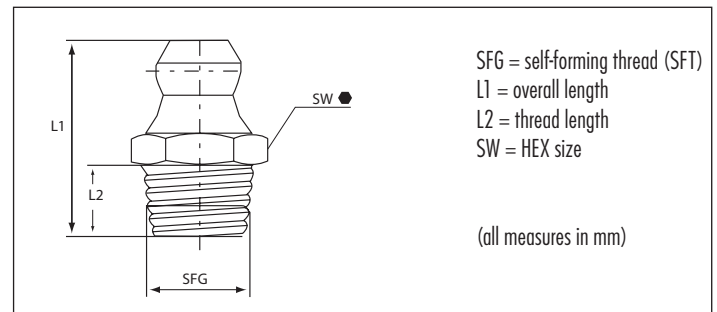

SFG	S 6 x 1			Ref.- No.:
L1	L2	SW	Steel	not available in other materials
13.5	4	7mm HEX	5317443	
15	5.5	7mm HEX	1100774	
17.5	5.5	7mm HEX	5241135	

SFG	S 8 x 1			Ref.- No.:
L1	L2	SW	Steel	not available in other materials
15	5.5	9mm HEX	1100975	
17	7	9mm HEX	5317541	

SFG	S 10 x 1			Ref.- No.:
L1	L2	SW	Steel	not available in other materials
15	5.5	11mm HEX	1101176	
18	8	11mm HEX	5241014	

Type H2/S

Hydraulic-Type Grease Nipples with Self-Forming Thread



- according to DIN 71412
- angled version B/45°
- with self-forming thread, tapered
- standard version made of steel, case-hardened according to DIN (head 550 HV/body 650 HV) and yellow passivated

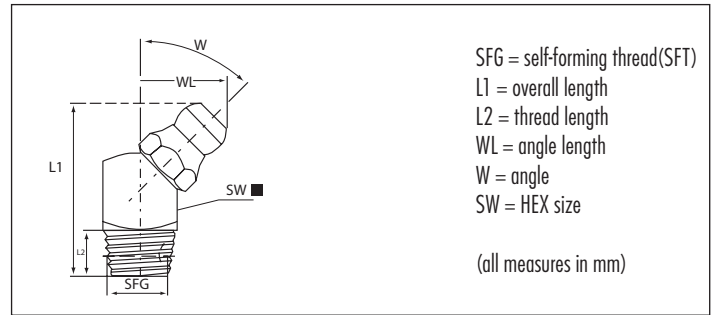

SFG S 6 x 1						Ref.- No.:
L1	L2	WL	W	SW	Steel	not available in other materials
20.5	5.5	10.5	45°	9mm SQ. ■	1204574	

SFG S 8 x 1						Ref.- No.:
L1	L2	WL	W	SW	Steel	not available in other materials
20.5	5.5	10.5	45°	9mm SQ. ■	1204575	

SFG S 10 x 1						Ref.- No.:
L1	L2	WL	W	SW	Steel	not available in other materials
20.5	5.5	11	45°	11mm SQ. ■	1204776	

SFG S 1/4" - 28						Ref.- No.:
L1	L2	WL	W	SW	Steel	not available in other materials
20.5	5.5	11	45°	9mm HEX ●	1200977	

Type H3/S

Hydraulic-Type Grease Nipples with Self-Forming Thread



- according to DIN 71412
- angled version C/90°
- with self-forming thread, tapered
- standard version made of steel, case-hardened according to DIN (head 550 HV/body 650 HV) and yellow passivated

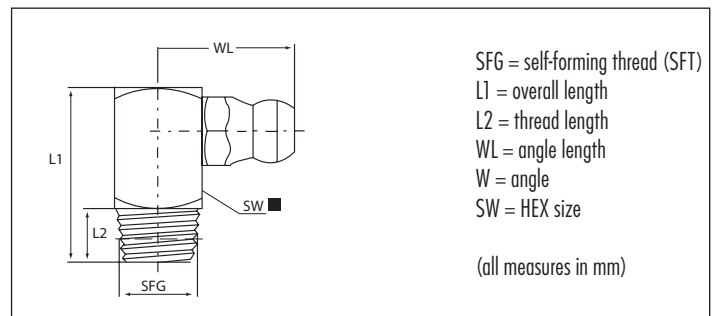

SFG S 6 x 1						Ref.- No.:
L1	L2	WL	W	SW	Steel	not available in other materials
18	5.5	14	90°	9mm SQ. ■	1304574	
21.5	5.5	14	90°	9mm SQ. ■	1304578	

SFG S 8 x 1						Ref.- No.:
L1	L2	WL	W	SW	Steel	not available in other materials
18	5.5	14	90°	9mm SQ. ■	1304575	

SFG S 10 x 1						Ref.- No.:
L1	L2	WL	W	SW	Steel	not available in other materials
18	5.5	15	90°	11mm SQ. ■	1304776	

UMETA HYDRAULIC-TYPE GREASE NIPPLES - DRIVE-IN VERSION

APPLICATION AREA

By using UMETA grease nipples with drive-in shank, you effectively save the thread-cutting process in the borehole.

VERSIONS

Drive-in nipples as standard version are with plain shank, made of steel, case-hardened, zinc-plated and passivated. Upon request, UMETA manufactures drive-in grease nipples in other versions, with respect to the following:

- dimension
- material
- shank length
- shank type (e.g. serrated ridge)
- shank diameter
- surface colour
- further surface treatment

MOUNTING INSTRUCTIONS

For straight-type grease nipples, we recommend using the drive-in tool, with which the nipple can be driven-in effectively and with care. The exact size of the core hole depends on the material and must be determined by mounting tests. The standard gauge for the installation bore diameter corresponds to the nominal width of the shank \varnothing .



OPERATING INSTRUCTIONS

Since this type of grease nipple is only driven in, it may get loose by

- strong vibrations
- high back-pressure when greasing with auto-matic guns
- pulling off the hydraulic coupler

Drive-in type hydraulic grease nipples should only be lubricated by a hydraulic nozzle.



RECOMMENDATION

Drive-in type grease nipples are only suitable for low pressures. Please check whether they can be replaced by self-forming nipples for a better fit.

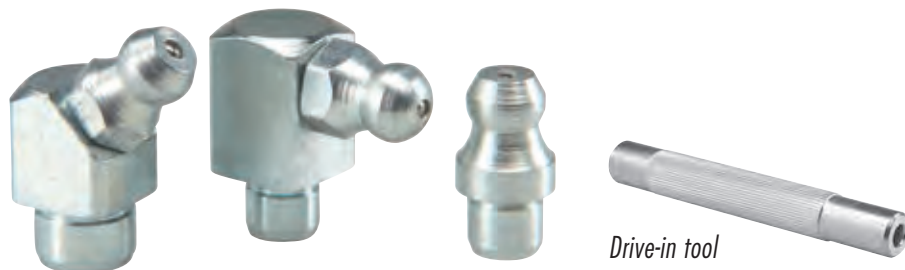

Type H1a

Hydraulic-Type Grease Nipples - Drive-in Version



- according to DIN 71412
- straight version A/180°
- drive-in-type with plain shank
- standard versions according to DIN are made of steel, case-hardened, zinc-plated and passivated
- for other types and materials, please see table, or upon request

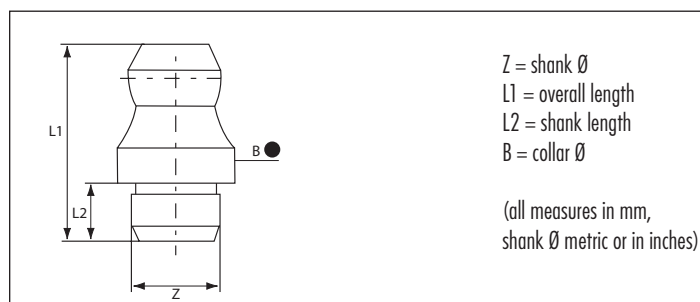

Z	5mm \varnothing			Ref.- No.:			
L1	L2	B	Steel	Brass	SST303	SST316L	
15	5.5	8 ●	1100185				

Z	6mm \varnothing			Ref.- No.:			
L1	L2	B	Steel	Brass	SST303	SST316L	
14	4	8 ●	5241040		5241097		
15	5.5	8 ●	1100186	1110186	1120186	1140186	
21	11	10 ●	5241029				

Z	6.35mm, 1/4" \varnothing			Ref.- No.:			
L1	L2	B	Steel	Brass	SST303	SST316L	
15	5.5	8 ●	1100187				

Z	8mm \varnothing			Ref.- No.:			
L1	L2	B	Steel	Brass	SST303	SST316L	
15	5.5	10 ●	1100288	1110288	1120288		
30	5.5	10 ●	1100289				

Z	10mm \varnothing			Ref.- No.:			
L1	L2	B	Steel	Brass	SST303	SST316L	
15	5.5	12 ●	1100389				

Z	5/16" \varnothing			Ref.- No.:			
L1	L2	B	Steel	Brass	SST303	SST316L	
15	5.5	10 ●	1100290				

Type H2a

Hydraulic-Type Grease Nipples - Drive-in Version



- according to DIN 71412
- angled version B/45°
- drive-in-type with plain shank
- standard versions according to DIN are made of steel, zinc-plated and passivated, head case-hardened

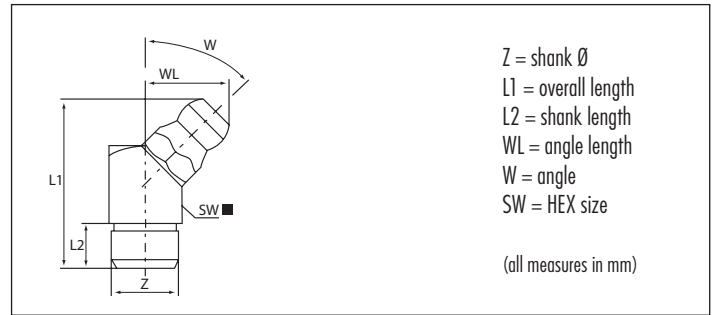

Z	6mm Ø					Ref.- No.:			
L1	L2	WL	W	SW	Steel	Brass	SST303	SST316L	
20.5	5.5	10.5	45°	9mm SQ. ■	1204586				

Z	10mm Ø					Ref.- No.:			
L1	L2	WL	W	SW	Steel	Brass	SST303	SST316L	
20.5	5.5	10.7	45°	11mm SQ. ■	1204789				

Z	8mm Ø					Ref.- No.:			
L1	L2	WL	W	SW	Steel	Brass	SST303	SST316L	
20.5	5.5	10.5	45°	9mm SQ. ■	1204588				

Type H3a

Hydraulic-Type Grease Nipples - Drive-in Version



- according to DIN 71412
- angled version C/90°
- drive-in-type with plain shank
- standard versions according to DIN are made of steel, zinc-plated and passivated, head case-hardened

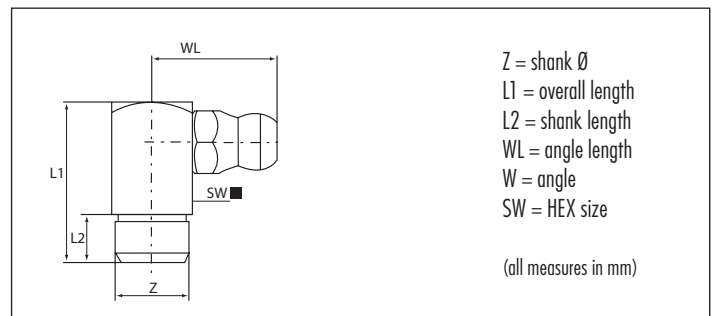

Z	6mm Ø					Ref.- No.:			
L1	L2	WL	W	SW	Steel	Brass	SST303	SST316L	
18	5.5	14	90°	9mm SQ. ■	1304586				

Z	10mm Ø					Ref.- No.:			
L1	L2	WL	W	SW	Steel	Brass	SST303	SST316L	
18	5.5	15	90°	11mm SQ. ■	1304789				

Z	8mm Ø					Ref.- No.:			
L1	L2	WL	W	SW	Steel	Brass	SST303	SST316L	
18	5.5	14	90°	9mm SQ. ■	1304588				

UMETA HYDRAULIC-TYPE GREASE NIPPLES - SPECIAL DESIGNS

The following types are representing only the most commonly used special-type nipples. For individual applications, UMETA manufactures hydraulic-type grease nipples with special equipment in other versions, with respect to the following:

- dimension
- material
- thread size
- thread form (e. g. with tapered thread)
- length



High-pressure hydraulic-type nipple with pin valve



- straight version A/180°
- made of steel, zinc-plated and passivated
- with special pin valve

Due to the special pin valve, the lubrication point will be sealed hermetically after the greasing operation. As a result, internal impulse-like pressures up to 400 bar (5,800 PSI) can be attained, depending on the respective application.

APPLICATION AREA

Heavy Industry, Heavy Vehicle Industry.

GW		M 10 x 1.0			Ref.- No.:			
L1	L2	SW	Steel	Brass	SST303	SST316L		
21	7.5	11mm HEX ●	5800049					
21	9	11mm HEX ●	5800052		5800050			

GW		R 1/8, 1/8 - 28 BSP			Ref.- No.:			
L1	L2	SW	Steel	Brass	SST303	SST316L		
21	7.5	11mm HEX ●	5800054		5800051			
21	9	11mm HEX ●	5800053					

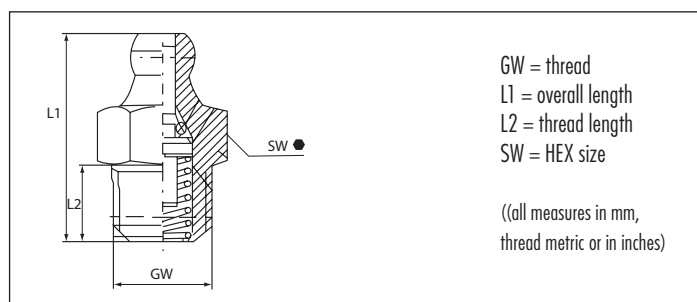

OPERATING INSTRUCTIONS

ATTENTION! During dismantling, utmost caution is required because of the possible pressure load. Dismantling should be done by experienced personnel only!

GW		G 1/8, 1/8 - 28 BSPP			Ref.- No.:			
L1	L2	SW	Steel	Brass	SST303	SST316L		
21	7	13mm HEX ●	5800056					

GW		G 1/4, 1/4 - 19 BSPP			Ref.- No.:			
L1	L2	SW	Steel	Brass	SST303	SST316L		
21	7	13mm HEX ●			5800057			

GW		1/8" - 27 NPT/PTF			Ref.- No.:			
L1	L2	SW	Steel	Brass	SST303	SST316L		
21	7.5	11mm HEX ●	5800048					
21	9	11mm HEX ●			5800040			

Hydraulic-type nipple with sealing element



- angled version B/45°
- made of steel, zinc-plated and passivated
- head hardened according to DIN
- with cylindrical thread
- with sintered sealing element under the collar

APPLICATION AREA

Heavy Industry, Heavy Vehicle Industry.

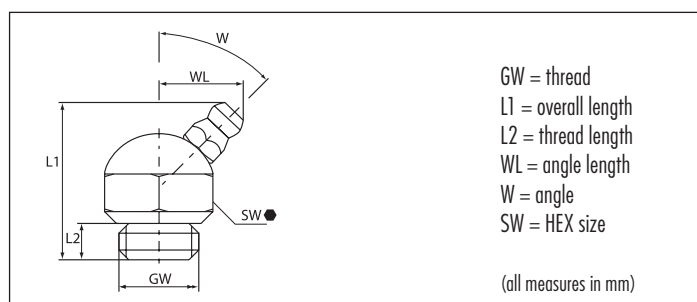

GW		M 14 x 2.0			Ref.- No.:			
L1	L2	WL	W	SW	Steel	Brass	SST303	SST316L
26.6	7	14	45°	19 mm HEX ●	5242042			

Hydraulic-type nipple, double headed



- made of steel, zinc-plated and passivated
- heads hardened according to DIN
- optionally available as:
 - H2-double head with 67° angle / hexagon body
 - H3-double head with 90° angle / square body

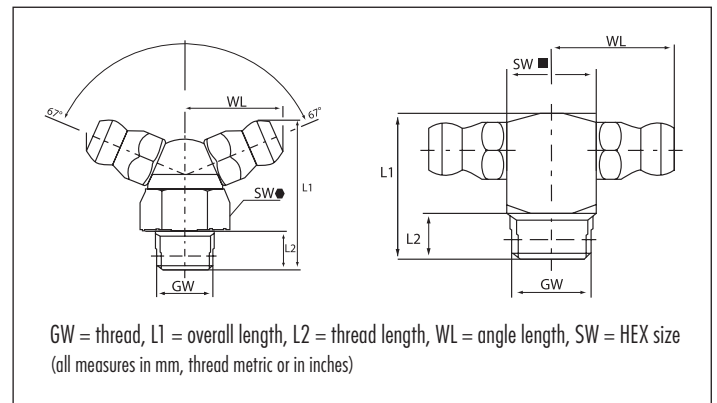

APPLICATION AREA

Option of alternative greasing by means of two heads.

GW		M 6 x 1.0				Ref.- No.:			
L1	L2	WL	W	SW	Steel	Brass	SST303	SST316L	
18	5.5	14.5	90°	9mm SQ. ■	5244179				

GW		M 8 x 1.0				Ref.- No.:			
L1	L2	WL	W	SW	Steel	Brass	SST303	SST316L	
18	5.5	14.5	90°	9mm SQ. ■	5244178				
18	5.5	14.5	90°	11mm SQ. ■	5244181				
20	5.5	13.5	67°	11mm HEX ●	5244159				

GW		M 8 x 1.25				Ref.- No.:			
L1	L2	WL	W	SW	Steel	Brass	SST303	SST316L	
18	5.5	14.5	90°	9mm SQ. ■	5244096				
20	5.5	13.5	67°	11mm HEX ●	5244160				
24	5.5	14.5	90°	9mm SQ. ■	5244033				

GW		M 10 x 1.0				Ref.- No.:			
L1	L2	WL	W	SW	Steel	Brass	SST303	SST316L	
18	5.5	15	90°	11mm SQ. ■	5244094		5244134		
20	5.5	13.5	67°	11mm HEX ●	5244161				
22	7	13.5	67°	11mm HEX ●	5244163				

GW		R 1/8, 1/8 - 28 BSP				Ref.- No.:			
L1	L2	WL	W	SW	Steel	Brass	SST303	SST316L	
18	5.5	15	90°	11mm SQ. ■	5244095				
20	5.5	13.5	67°	11mm HEX ●	5244162				

Hydraulic-type nipple with extension



- straight version A/180°
- made of steel, zinc-plated and passivated
- head hardened according to DIN
- with tapered thread
- with press-fitted extension for exact grease flow

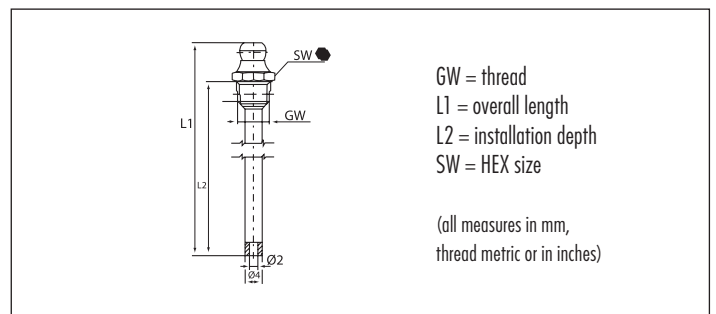

APPLICATION AREA

For deep seated lubrication points, which can be serviced sufficiently through the extension, e.g. for drive shafts.

GW		M 8 x 1.0			Ref.- No.:			
L1	L2	SW	Steel	Brass	SST303	SST316L		
75	65	9mm HEX ●	5241130					
130	120	9mm HEX ●	5241133					

GW		M 8 x 1.25			Ref.- No.:			
L1	L2	SW	Steel	Brass	SST303	SST316L		
32	22	9mm HEX ●	5241213					

GW		M 10 x 1.0			Ref.- No.:			
L1	L2	SW	Steel	Brass	SST303	SST316L		
59	49	11mm HEX ●	5241140					
75	65	11mm HEX ●	5241132					

GW		5/16" - 24 NF/UNF/SAE			Ref.- No.:			
L1	L2	SW	Steel	Brass	SST303	SST316L		
75	65	9mm HEX ●	5241131					

UMETA BALL-TYPE GREASE NIPPLES ACCORDING TO FORMER DIN 3402

APPLICATION AREA

UMETA ball-type nipples are suitable for all standard lubrication points, which have to be frequently lubricated in a reliable way. They are more and more often replaced by hydraulic-type grease nipples according to DIN 71412 due to their manifold application purposes.

VERSIONS

In general, our ball-type grease nipples according to DIN are made of steel, zinc-plated and passivated, and they are featured with a tapered thread. The head diameter is 6.5 (-0.2) mm / 0.256" (-0.008"). We offer various standard types also in brass or stainless steel 1.4305 ~ ASTM 303 and 1.4404 ~ ASTM 316L (V2A/V4A). Of course, our ball-type grease nipples are also available in different angle versions, or as drive-in type.

On request, UMETA manufactures ball-type nipples in other versions, with respect to the following:

- dimension
- material
- thread size
- thread form (e. g. with cylindrical thread)
- opening pressure
- surface colour (e. g. yellow passivated)
- further surface treatment
- etc.

OPERATING INSTRUCTIONS

As suitable lubricating nozzle, we recommend our hollow-type nozzles or hydraulic nozzles by using our push-type grease guns type A+B.



Type K1



Ball-Type Grease Nipples

- according to former DIN 3402
- straight version A/180°
- standard versions according to DIN are made of steel, zinc-plated and passivated, with tapered thread
- for other types and materials, please see table, or upon request

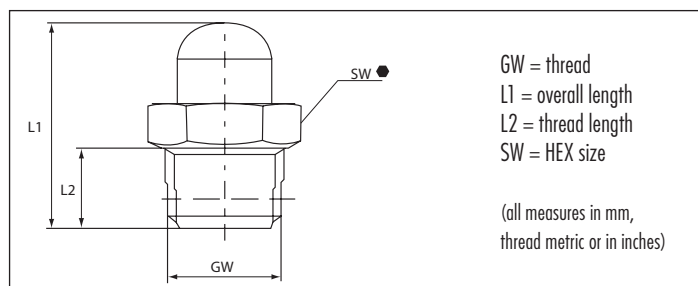

GW		M 5 x 0.8		Ref.- No.:			
L1	L2	SW	Steel	Brass	SST303	SST316L	
14	5.5	7mm HEX	2100701	2110702			

GW		M 6 x 0.75		Ref.- No.:			
L1	L2	SW	Steel	Brass	SST303	SST316L	
14	5.5	7mm HEX	2100703	2110703			

GW		M 6 x 1.0		Ref.- No.:			
L1	L2	SW	Steel	Brass	SST303	SST316L	
14	5.5	7mm HEX	2100704	2110704	2120704		

GW		M 7 x 1.0		Ref.- No.:			
L1	L2	SW	Steel	Brass	SST303	SST316L	
14	5.5	9mm HEX	2100905				

GW		M 8 x 1.0		Ref.- No.:			
L1	L2	SW	Steel	Brass	SST303	SST316L	
14	5.5	9mm HEX	2100907	2110907	2120907		

GW		M 8 x 1.25		Ref.- No.:			
L1	L2	SW	Steel	Brass	SST303	SST316L	
14	5.5	9mm HEX	2100908				

GW		M 10 x 1.0		Ref.- No.:			
L1	L2	SW	Steel	Brass	SST303	SST316L	
14	5.5	11mm HEX	2101109				

GW		M 10 x 1.5		Ref.- No.:			
L1	L2	SW	Steel	Brass	SST303	SST316L	
14	5.5	11mm HEX	2101111				

GW		R 1/8, 1/8 - 28 BSP		Ref.- No.:			
L1	L2	SW	Steel	Brass	SST303	SST316L	
14	5.5	11mm HEX	2101156	2111156			

GW		R 1/4, 1/4 - 19 BSP		Ref.- No.:			
L1	L2	SW	Steel	Brass	SST303	SST316L	
16	6.5	14mm HEX	2101457	2111457			

GW		R 3/8, 3/8 - 19 BSP		Ref.- No.:			
L1	L2	SW	Steel	Brass	SST303	SST316L	
17.5	8	17mm HEX	2101758				

Type K2

Ball-Type Grease Nipples

- according to former DIN 3402
- angled version B/45°
- standard versions according to DIN are made of steel, zinc-plated and passivated, with tapered thread

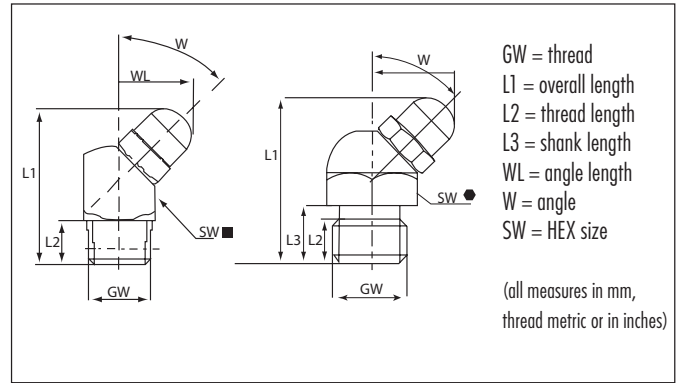

GW	M 6 x 1.0						Ref.- No.:			
L1	L2	L3	WL	W	SW	Steel	Brass	SST303	SST316L	
19	5.5	9	45°	9 mm SQ.	■	2204504				

GW	M 8 x 1.0						Ref.- No.:			
L1	L2	L3	WL	W	SW	Steel	Brass	SST303	SST316L	
19	5.5	9	45°	9 mm SQ.	■	2204507				

GW	M 8 x 1.25						Ref.- No.:			
L1	L2	L3	WL	W	SW	Steel	Brass	SST303	SST316L	
19	5.5	9	45°	9mm SQ.	■	2204508				
19	5.5	9	45°	11mm HEX	●	2111458				
20	5.5	6	9.5	45°	11mm HEX	●	2111470			

GW	M 10 x 1.0						Ref.- No.:			
L1	L2	L3	WL	W	SW	Steel	Brass	SST303	SST316L	
14	5.5	9.5	45°	11mm SQ.	■	2204709				

GW	M 10 x 1.5						Ref.- No.:			
L1	L2	L3	WL	W	SW	Steel	Brass	SST303	SST316L	
20	5.5	6	9.5	45°	11mm HEX	●		2111471		
27	5.5	9.5	9.5	45°	11mm HEX	●	2204711			

GW	R 1/8, 1/8 - 28 BSP						Ref.- No.:			
L1	L2	L3	WL	W	SW	Steel	Brass	SST303	SST316L	
14	5.5	9.5	45°	11mm SQ.	■	2204756				
14	5.5	9.5	45°	11mm HEX	●			2111460		

GW	R 1/4, 1/4 - 19 BSP						Ref.- No.:			
L1	L2	L3	WL	W	SW	Steel	Brass	SST303	SST316L	
22	6.5	11.5	45°	14mm HEX	●	2201457				

Typ K3

Ball-Type Grease Nipples

- according to former DIN 3402
- elbow version C/90°
- standard versions according to DIN are made of steel, zinc-plated and passivated, with tapered thread

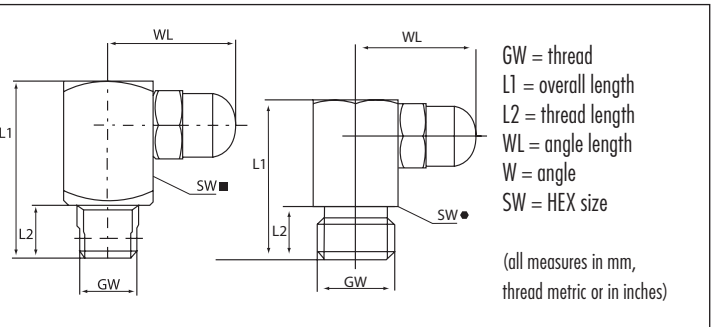

GW	M 6 x 1.0					Ref.- No.:			
L1	L2	WL	W	SW	Steel	Brass	SST303	SST316L	
18	5.5	13	90°	9 mm SQ.	■	2304504			

GW	M 8 x 1.0					Ref.- No.:			
L1	L2	WL	W	SW	Steel	Brass	SST303	SST316L	
18	5.5	13	90°	9 mm SQ.	■	2304507			

GW	M 8 x 1.25					Ref.- No.:			
L1	L2	WL	W	SW	Steel	Brass	SST303	SST316L	
18	5.5	13	90°	9mm SQ.	■	2304508			
18	5.5	13	90°	9mm HEX	●			2111461*	
19	5.5	13	90°	11mm HEX	●			2111468*	

GW	M 10 x 1.0					Ref.- No.:			
L1	L2	WL	W	SW	Steel	Brass	SST303	SST316L	
18	5.5	14	90°	11mm SQ.	■	2304709			

GW	M 10 x 1.5 (cyl.)					Ref.- No.:			
L1	L2	WL	W	SW	Steel	Brass	SST303	SST316L	
19	5.5	13	90°	11mm HEX	●			2111469*	

GW	R 1/8, 1/8 - 28 BSP					Ref.- No.:			
L1	L2	WL	W	SW	Steel	Brass	SST303	SST316L	
18	5.5	14	90°	11mm SQ.	■	2304756			

GW	R 1/4, 1/4 - 19 BSP					Ref.- No.:			
L1	L2	WL	W	SW	Steel	Brass	SST303	SST316L	
22.5	6.5	15	90°	14mm HEX	●	2301457			

* cylindric

UMETA BALL-TYPE GREASE NIPPLES - DRIVE-IN VERSION

APPLICATION AREA

By using UMETA grease nipples with drive-in shank, you effectively save the thread-cutting process in the borehole.

VERSIONS

Drive-in nipples as standard version are with plain shank, made of steel, zinc-plated and passivated. Upon request, UMETA manufactures drive-in grease nipples in other versions, with respect to the following:

- dimension
- material
- shank length
- shank type (e. g. serrated ridge)
- shank diameter
- surface colour
- further surface treatment

MOUNTING INSTRUCTIONS

For straight-type grease nipples, we recommend using the drive-in tool, with which the nipple can

be driven-in effectively and with care. The exact size of the core hole depends on the material and must be determined by mounting tests.

The standard gauge for the installation bore diameter corresponds to the nominal width of the shank \varnothing .



Drive-in tool

OPERATING INSTRUCTIONS

Since this type of grease nipple is only driven in, it may get loose by

- strong vibrations
- high back-pressure when greasing with automatic guns
- pulling off the hydraulic coupler.

Drive-in type hydraulic grease nipples should only be lubricated by a hydraulic nozzle.



RECOMMENDATION

Drive-in type grease nipples are only suitable for low pressures. Please check whether they can be replaced by self-forming nipples for a better fit.



Type K1a



Ball-Type Grease Nipples - Drive-in Version

- according to former DIN 3402
- straight version A/180°
- drive-in-type with plain shank
- standard versions according to DIN are made of steel, zinc-plated and passivated
- for other types and materials, please see table, or upon request

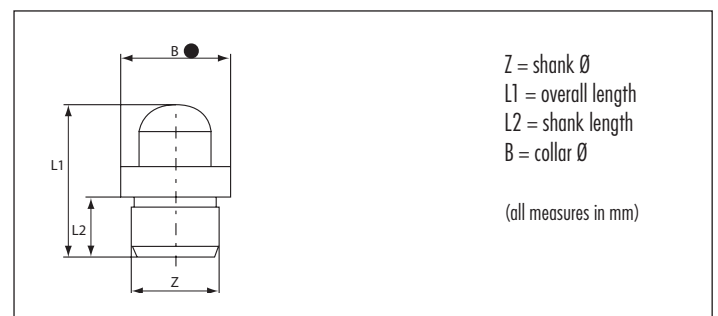

Z	6mm \varnothing	Ref.- No.:	Steel	Brass	SST303	SST316L
L1	L2	B				
14	5.5	8 ●	2100186	2110186	2120186	
15	6.5	8 ●		2110187		

Z	8mm \varnothing	Ref.- No.:	Steel	Brass	SST303	SST316L
L1	L2	B				
14	5.5	10 ●	2100288	2110288	2120288	

Z	10mm \varnothing	Ref.- No.:	Steel	Brass	SST303	SST316L
L1	L2	B				
14	5.5	12 ●	2100389			

Type K2a

Ball-Type Grease Nipples - Drive-in Version



- according to former DIN 3402
- angled version B/45°
- drive-in-type with plain shank
- standard versions according to DIN are made of steel, zinc-plated and passivated

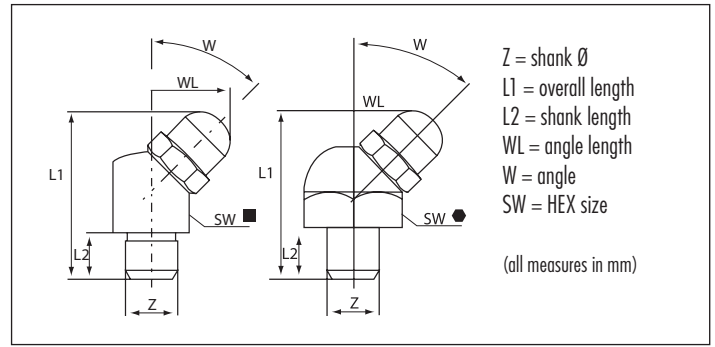

Z	6mm Ø					Ref.- No.:			
L1	L2	WL	W	SW	Steel	Brass	SST303	SST316L	
19	5.5	9	45°	9mm SQ. ■	2204586				
21	7	9	45°	9mm HEX ●		2111467			

Z	10mm Ø					Ref.- No.:			
L1	L2	WL	W	SW	Steel	Brass	SST303	SST316L	
19	5.5	9.5	45°	11mm SQ. ■	2204789				

Z	8mm Ø					Ref.- No.:			
L1	L2	WL	W	SW	Steel	Brass	SST303	SST316L	
19	5.5	9	45°	9mm SQ. ■	2204588				
21	7	9	45°	9mm HEX ●		2111466			

Type K3a

Ball-Type Grease Nipples - Drive-in Version



- according to former DIN 3402
- angled version C/90°
- drive-in-type with plain shank
- standard versions according to DIN are made of steel, zinc-plated and passivated

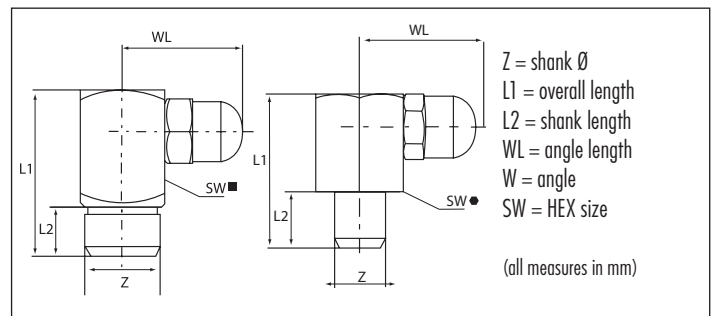

Z	6mm Ø					Ref.- No.:			
L1	L2	WL	W	SW	Steel	Brass	SST303	SST316L	
18	5.5	13	90°	9mm SQ. ■	2304586				
18	5.5	13	90°	9mm HEX ●		2111462			
19	5.5	13	90°	11mm HEX ●		2111463			

Z	8mm Ø					Ref.- No.:			
L1	L2	WL	W	SW	Steel	Brass	SST303	SST316L	
18	5.5	13	90°	9mm SQ. ■	2304588				
19	5.5	13	90°	11mm HEX ●		2111464			

UMETA FLUSH-TYPE GREASE NIPPLES ACCORDING TO DIN 3405

APPLICATION AREA

Flush-type grease nipples are particularly suitable for installations where extending or protruding nipples cannot be used.

VERSIONS

In general, our flush-type grease nipples according to DIN are made of steel, zinc-plated and passivated, and they are featured with a cylindrical thread. Of course, our flush-type nipples are also available in different angle versions, with a self-forming thread, or as drive-in type. We offer various standard types also in brass or stainless steel 1.4305 ~ ASTM 303 (V2A).

Upon request, UMETA manufactures flush-type grease nipples in other versions, with respect to the following:

- dimension
- material
- thread size
- thread form (e. g. with tapered thread)
- opening pressure
- surface colour (e. g. yellow passivated)
- further surface treatment
- etc.

OPERATING INSTRUCTIONS

Flush-type nipples are only suitable for press-greasing by means of a UMETA extension tube or a UMETA push-type grease gun with pin-pointed, pointed, or combi-nozzle.



Type D1



Flush-Type Grease Nipples

- according to DIN 3405
- straight version A/180°
- standard versions according to DIN are made of steel, zinc-plated and passivated, with cylindrical thread
- for other types and materials, please see table, or upon request

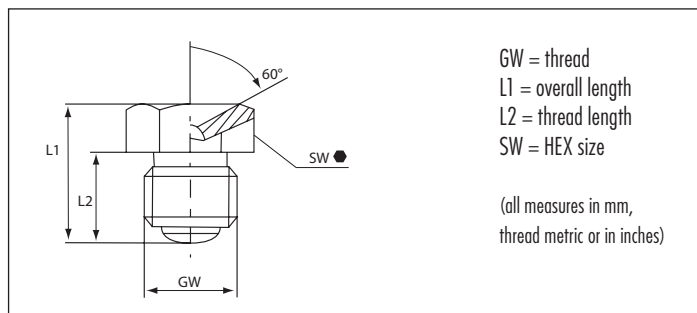

GW M 5 x 0.8			Ref.- No.:			
L1	L2	SW	Steel	Brass	SST303	SST316L
9	6	7mm HEX	3100720			

GW M 6 x 0.75			Ref.- No.:			
L1	L2	SW	Steel	Brass	SST303	SST316L
9	6	7mm HEX	3100723			

GW M 6 x 1.0			Ref.- No.:			
L1	L2	SW	Steel	Brass	SST303	SST316L
9	6	7mm HEX	3100724	3110724	3120724	

GW M 8 x 1.0			Ref.- No.:			
L1	L2	SW	Steel	Brass	SST303	SST316L
9.5	6.5	9mm HEX	3100925	3110925	3120925	

GW M 8 x 1.25			Ref.- No.:			
L1	L2	SW	Steel	Brass	SST303	SST316L
9.5	6.5	9mm HEX	3100926	3110926	3120926	

GW M 10 x 1.0			Ref.- No.:			
L1	L2	SW	Steel	Brass	SST303	SST316L
9.5	6.5	11mm HEX	3101127	3111127	3121127	

GW M 10 x 1.5			Ref.- No.:			
L1	L2	SW	Steel	Brass	SST303	SST316L
9.5	6.5	11mm HEX	3101128			

GW M 12 x 1.5			Ref.- No.:			
L1	L2	SW	Steel	Brass	SST303	SST316L
14	9.5	14mm HEX	3101431			

GW G 1/8, 1/8 - 28 BSPP			Ref.- No.:			
L1	L2	SW	Steel	Brass	SST303	SST316L
9.5	6.5	11mm HEX	3101161	3111161	3121161	

GW G 1/4, 1/4 - 19 BSPP			Ref.- No.:			
L1	L2	SW	Steel	Brass	SST303	SST316L
14	9.5	14mm HEX	3101462	3111462	3121462	

GW G 3/8, 3/8 - 19 BSPP			Ref.- No.:			
L1	L2	SW	Steel	Brass	SST303	SST316L
14.5	9	17mm HEX	3101763			

GW 1/4" - 28 NF/UNF/SAE			Ref.- No.:			
L1	L2	SW	Steel	Brass	SST303	SST316L
9	6	7mm HEX	3100742			

Type D2

Flush-Type Grease Nipples



- according to DIN 3405
- angled version B/45°
- standard versions according to DIN are made of steel, zinc-plated and passivated, with tapered thread

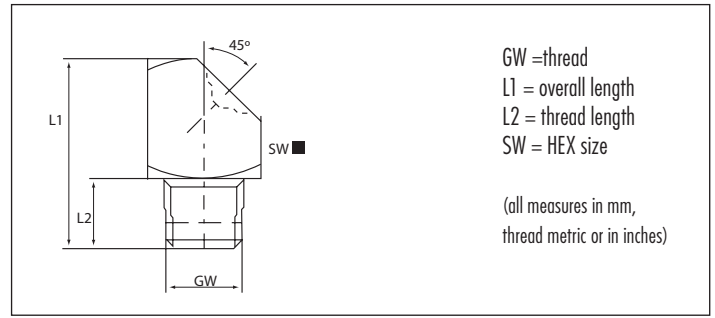

GW M 6 x 1.0				Ref.- No.:			
L1	L2	W	SW	Steel	Brass	SST303	SST316L
15	5.5	45°	9mm SQ. ■	3204504	3214504		

GW M 10 x 1.0				Ref.- No.:			
L1	L2	W	SW	Steel	Brass	SST303	SST316L
15	5.5	45°	11mm SQ. ■	3204709			

GW M 8 x 1.0				Ref.- No.:			
L1	L2	W	SW	Steel	Brass	SST303	SST316L
15	5.5	45°	9mm SQ. ■	3204507			

GW R 1/8, 1/8 - 28 BSP				Ref.- No.:			
L1	L2	W	SW	Steel	Brass	SST303	SST316L
15	5.5	45°	11mm SQ. ■	3204756			

GW M 8 x 1.25				Ref.- No.:			
L1	L2	W	SW	Steel	Brass	SST303	SST316L
15	5.5	45°	9mm SQ. ■	3204508			

Type D3

Flush-Type Grease Nipples



- according to DIN 3405
- angled version C/90°
- standard versions according to DIN are made of steel, zinc-plated and passivated, with tapered thread

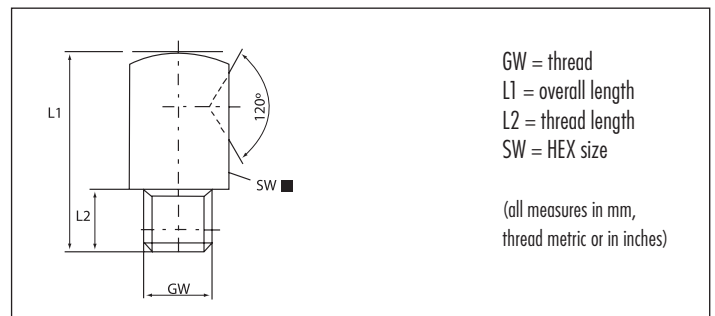

GW M 6 x 1.0				Ref.- No.:			
L1	L2	W	SW	Steel	Brass	SST303	SST316L
18	5.5	90°	9mm SQ. ■	3304504			

GW M 10 x 1.0				Ref.- No.:			
L1	L2	W	SW	Steel	Brass	SST303	SST316L
18	5.5	90°	11mm SQ. ■	3304709			

GW M 8 x 1.0				Ref.- No.:			
L1	L2	W	SW	Steel	Brass	SST303	SST316L
18	5.5	90°	9mm SQ. ■	3304507			

GW R 1/8, 1/8 - 28 BSP				Ref.- No.:			
L1	L2	W	SW	Steel	Brass	SST303	SST316L
18	5.5	90°	11mm SQ. ■	3304756			

GW M 8 x 1.25				Ref.- No.:			
L1	L2	W	SW	Steel	Brass	SST303	SST316L
18	5.5	90°	9mm SQ. ■	3304508			

FLUSH-TYPE GREASE NIPPLES WITH SELF-FORMING THREAD

APPLICATION AREA

By using UMETA grease nipples with self-forming thread (SFT / SFG) you effectively save the thread-cutting process in the borehole.

VERSIONS

For safety reasons and in order to avoid abrasion wear, the DIN standard for grease nipples with self-forming thread demands a specific surface hardness of 650 HV minimum as well as a particularly wide flank angle of 105° at the thread. Therefore, we operate this decisive process in our own curing oven. For a better visual distinction, UMETA self-forming grease nipples are yellow passivated. Upon request, they are also available in another surface colour, e. g. blue passivated = silver coloured.

MOUNTING INSTRUCTIONS

The special thread angle and the specific hardness level allow these grease nipples to be driven and screwed into holes without prior thread cutting. Thus, the thread of the grease nipple forms its counter thread. Later, the grease nipple can easily be screwed out and be replaced by a standard grease nipple. The exact size of the core hole depends on the material and must be determined by mounting tests. The consistency of the receiving material is decisive. The standard gauge for the installation bore diameter of 0.4-0.5 mm (0.02") below nominal width have proved in daily use.

OPERATING INSTRUCTIONS

As suitable lubricating nozzle, we recommend our pointed nozzles.

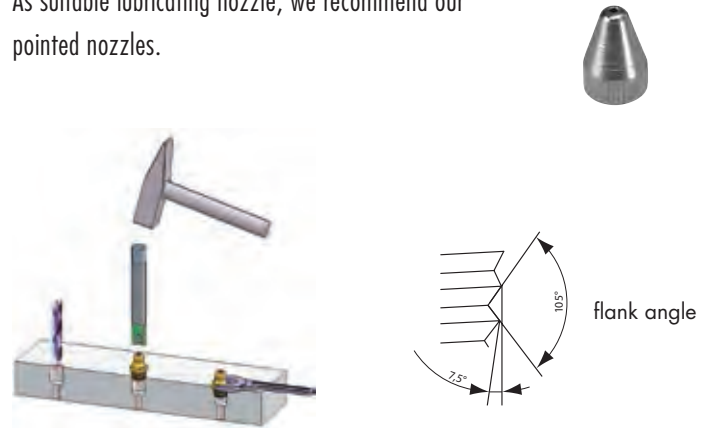

Type D1/S

Flush-Type Grease Nipples with Self-Forming Thread



- according to DIN 3405
- straight version A/180°
- with self-forming thread, tapered
- standard version made of steel, case-hardened according to DIN (650HV) and yellow passivated

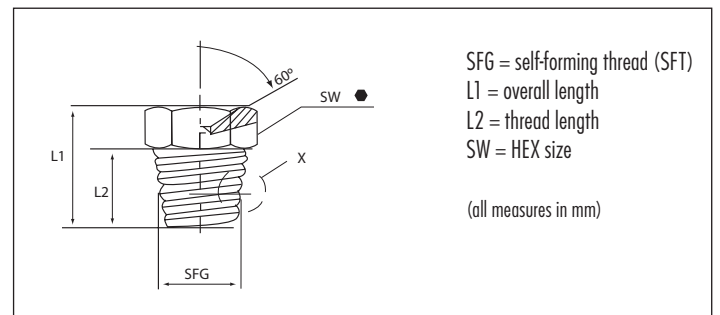

SFG	S 6 x 1	Ref.- No.:		
L1	L2	SW	Steel	not available in other materials
8.5	5.5	7mm HEX	●	3100774

SFG	S 10 x 1	Ref.- No.:		
L1	L2	SW	Steel	not available in other materials
8.5	5.5	11mm HEX	●	3101176

SFG	S 8 x 1	Ref.- No.:		
L1	L2	SW	Steel	not available in other materials
8.5	5.5	9mm HEX	●	3100975

FLUSH-TYPE GREASE NIPPLES - DRIVE-IN VERSION

APPLICATION AREA

By using UMETA grease nipples with drive-in shank, you effectively save the thread-cutting process in the borehole.

VERSIONS

Drive-in nipples as standard version are with plain shank, made of steel, zinc-plated and passivated. Upon request, UMETA manufactures drive-in grease nipples in other versions, with respect to the following:

- dimension
- material
- shank length
- shank type (e. g. serrated ridge)
- shank diameter
- surface colour
- further surface treatment

MOUNTING INSTRUCTIONS

The exact size of the core hole depends on the material and must be determined by mounting tests. The standard gauge for the installation bore diameter corresponds to the nominal width of the shank \varnothing .



RECOMMENDATION

Drive-in type grease nipples are only suitable for low pressures. Please check whether they can be replaced by self-forming nipples for a better fit.

OPERATING INSTRUCTIONS

Since this type of grease nipple is only driven in, it may get loose by

- strong vibrations
- high back-pressure when greasing with automatic guns

Drive-in type grease nipples, flush-type, should only be lubricated by a pointed nozzle.



Type D1a

Flush-Type Grease Nipples - Drive-in Version



- according to DIN 3405
- straight version A/180°
- drive-in-type with plain shank
- standard versions according to DIN are made of steel, zinc-plated and passivated
- for other types and materials, please see table, or upon request

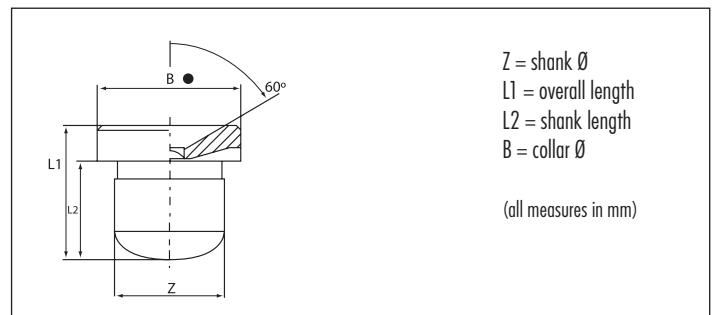

Z	5mm \varnothing			Ref.- No.:			
L1	L2	B	Steel	Brass	SST303	SST316L	
7.5	5.5	8	●				3100185

Z	8mm \varnothing			Ref.- No.:			
L1	L2	B	Steel	Brass	SST303	SST316L	
9.5	6.5	10	●				3100288 3110288 3120288

Z	6mm \varnothing			Ref.- No.:			
L1	L2	B	Steel	Brass	SST303	SST316L	
7.5	5.5	8	●				3100186 3110186 3120186

Z	10mm \varnothing			Ref.- No.:			
L1	L2	B	Steel	Brass	SST303	SST316L	
9.5	6.5	12	●				3100389 3110389

Z	6.35mm, 1/4" \varnothing			Ref.- No.:			
L1	L2	B	Steel	Brass	SST303	SST316L	
7.5	5.5	8	●				3100187

Type D2a



Flush-Type Grease Nipples - Drive-in Version

- according to DIN 3405
- angled version B/45°
- drive-in-type with plain shank
- standard versions according to DIN are made of steel, zinc-plated and passivated

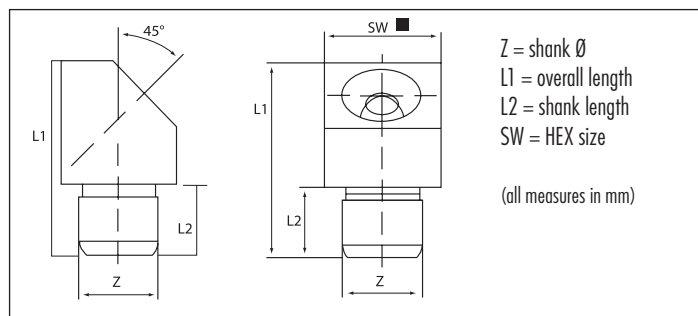

Z	6mm Ø				Ref.- No.:			
L1	L2	W	SW	Steel	Brass	SST303	SST316L	
15	5.5	45°	9mm SQ. ■	3204586				

Z	10mm Ø				Ref.- No.:			
L1	L2	W	SW	Steel	Brass	SST303	SST316L	
15	5.5	45°	11mm SQ. ■	3204789				

Z	8mm Ø				Ref.- No.:			
L1	L2	W	SW	Steel	Brass	SST303	SST316L	
15	5.5	45°	9mm SQ. ■	3204588				

Type D3a



Flush-Type Grease Nipples - Drive-in Version

- according to DIN 3405
- angled version C/90°
- drive-in-type with plain shank
- standard versions according to DIN are made of steel, zinc-plated and passivated

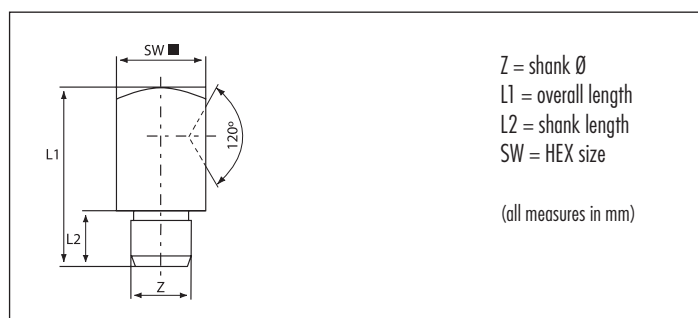

Z	6mm Ø				Ref.- No.:			
L1	L2	W	SW	Steel	Brass	SST303	SST316L	
18	5.5	90°	9mm SQ. ■	3304586				

Z	10mm Ø				Ref.- No.:			
L1	L2	W	SW	Steel	Brass	SST303	SST316L	
18	5.5	90°	11mm SQ. ■	3304789				

Z	8mm Ø				Ref.- No.:			
L1	L2	W	SW	Steel	Brass	SST303	SST316L	
18	5.5	90°	9mm SQ. ■	3304588				

FLUSH-TYPE GREASE NIPPLES - SPECIAL DESIGNS

VERSIONS

The following types are representing only the most commonly used special-type nipples. For individual applications, UMETA manufactures flush-type grease nipples with special equipment in other versions, with respect to the following:

- dimension
- material
- thread size
- thread form (e. g. with tapered thread)
- length



Type DV1

Flush-Type Grease Nipples

- without collar, with slot for screwdriver
- for even mounting without projection
- straight version A/180°
- made of steel, zinc-plated and passivated, with cylindrical thread



GW	M 8 x 1.0	Ref.- No.:	
L1		Steel	Brass SST303 SST316L
10		5243010	5243069 5243021

GW	M 10 x 1.0	Ref.- No.:	
L1		Steel	Brass SST303 SST316L
10		5243018	5243067

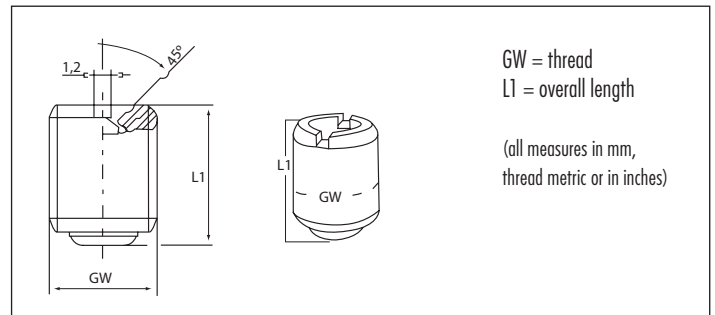

GW	G 1/8, 1/8 - 28 BSPP	Ref.- No.:	
L1		Steel	Brass SST303 SST316L
10		5243019	5243068

GW	G 1/4	Ref.- No.:	
L1		Steel	Brass SST303 SST316L
13		5243020	

Type D3 quattro 90°

Flush-Type Grease Nipples

- made of steel, zinc-plated and passivated, with tapered thread

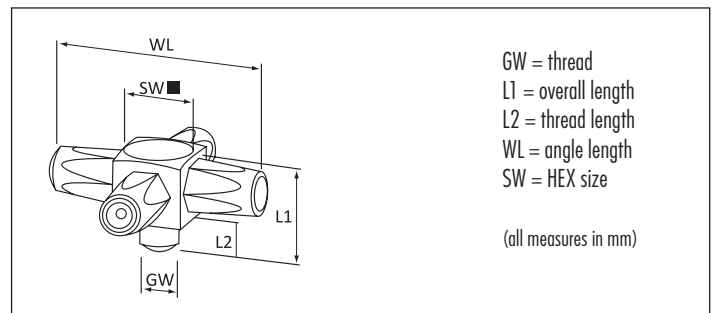

GW	M 6 x 1.0	Ref.- No.:	
L1	L2 WL W SW	Steel	Brass SST303 SST316L
15.5	5.5 33 90° 11mm SQ. ■	5244185	

■ UMETA BUTTON-HEAD GREASE NIPPLES ACCORDING TO DIN 3404

APPLICATION AREA

UMETA button-head grease nipples are particularly suitable for lubricating points with a big grease volume because of their specific high flow-rate of grease. As another result of the robust construction, these grease nipples are preferably used in the construction machinery.

VERSIONS

The UMETA button-head grease nipples are available in four different sizes:

- head Ø 10 mm = M4
- head Ø 16 mm = M1
- head Ø 22 mm = M22
- head hexagon-type, Hex size 15 mm = T1

In general, our button-head grease nipples according to DIN are made of steel, zinc-plated and passivated, and they are featured with a cylindrical thread. We offer various standard types also in brass or stainless steel 1.4305 ~ ASTM 303 and 1.4404 ~ ASTM 316L (V2A/V4A).

Upon request, UMETA manufactures button-head grease nipples in other versions, with respect to the following:

- dimension
- material
- thread size
- thread form (e. g. with tapered thread)
- opening pressure
- surface colour (e. g. yellow passivated)
- further surface treatment
- etc.

MOUNTING INSTRUCTIONS

In order to allow for a proper lubrication with all common grease guns, the head space, which is necessary for installation, should be considered (please see table with dimensions).

OPERATING INSTRUCTIONS

As suitable lubricating nozzle, we recommend our button-head coupler.



Type M4



Button-Head Grease Nipples

- head Ø 10 mm
- according to DIN 3404
- straight version A/180°
- standard versions according to DIN are made of steel, zinc-plated and passivated, with cylindrical thread
- for other types and materials, please see table, or upon request

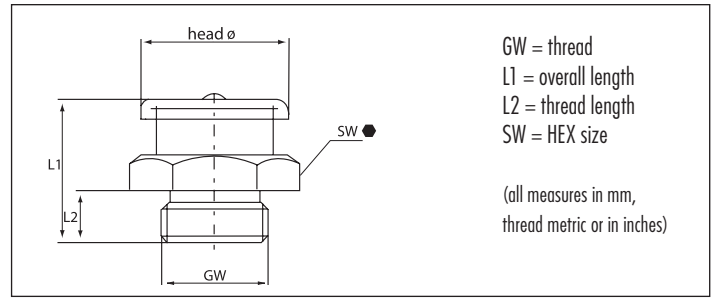

GW	M 6 x 1.0	Ref.- No.:	Steel	Brass	SST303	SST316L
L1	L2	SW				
13.5	6	11mm HEX	4201104			

GW	M 8 x 1.0	Ref.- No.:	Steel	Brass	SST303	SST316L
L1	L2	SW				
13.5	6	11mm HEX	4201107			

GW	M 10 x 1.0	Ref.- No.:	Steel	Brass	SST303	SST316L
L1	L2	SW				
13.5	6	11mm HEX	4201109			

GW	G 1/8, 1/8 - 28 BSPP	Ref.- No.:	Steel	Brass	SST303	SST316L
L1	L2	SW				
13.5	6	11mm HEX	4201161	4221161		

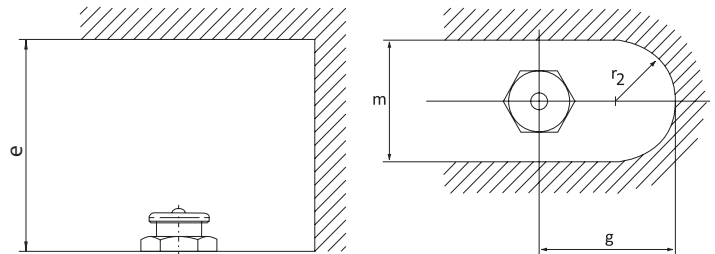

Instructions for installation: necessary space			
e =	50 mm/2-11/64"	r =	14 mm/41/64"
m =	26 mm/1-17/64"	g =	30 mm/1-25/64"

Type M1



Button-Head Grease Nipples

- head Ø 16 mm
- according to DIN 3404
- straight version A/180°
- standard versions according to DIN are made of steel, zinc-plated and passivated, with cylindrical thread
- for other types and materials, please see table, or upon request

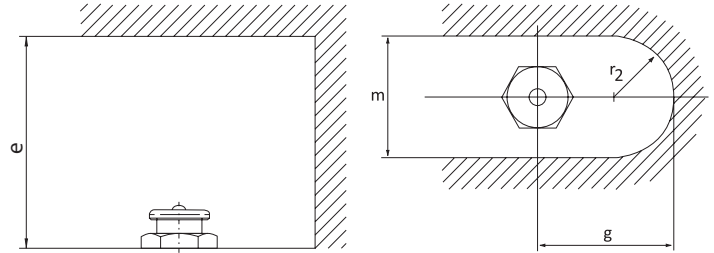
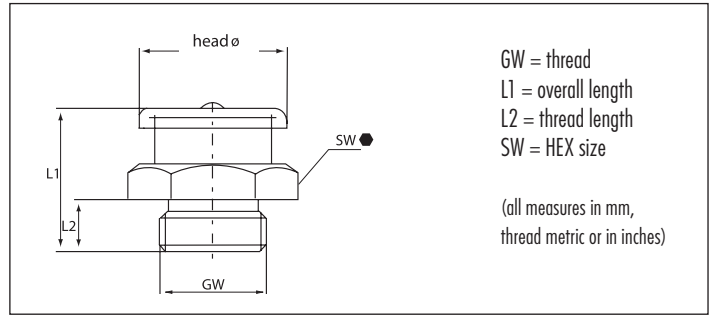

Instructions for installation: necessary space

e =	55 mm/2-11/64"	r =	16 mm/41/64"
m =	32 mm/1-17/64"	g =	35 mm/1-25/64"

GW	M 6 x 1.0	Ref.- No.:	Steel	Brass	SST303	SST316L
L1	L2	SW				
17	6	17mm HEX ●	4101704	4111704	4121704	4141704

GW	M 8 x 1.0	Ref.- No.:	Steel	Brass	SST303	SST316L
L1	L2	SW				
17	6	17mm HEX ●	4101707	4111707	4121707	4141707

GW	M 8 x 1.25	Ref.- No.:	Steel	Brass	SST303	SST316L
L1	L2	SW				
17	6	17mm HEX ●	4101708	4111708	4121708	

GW	M 10 x 1.0	Ref.- No.:	Steel	Brass	SST303	SST316L
L1	L2	SW				
17	6	17mm HEX ●	4101709	4111709	4121709	4141709
20	9	17mm HEX ●	4101713			

GW	M 10 x 1.5	Ref.- No.:	Steel	Brass	SST303	SST316L
L1	L2	SW				
17	6	17mm HEX ●	4101711	4111711	4121711	

GW	M 12 x 1.0	Ref.- No.:	Steel	Brass	SST303	SST316L
L1	L2	SW				
17	6	17mm HEX ●	4101732			

GW	M 12 x 1.5	Ref.- No.:	Steel	Brass	SST303	SST316L
L1	L2	SW				
17	6	17mm HEX ●	4101714	4111714	4121714	

GW	M 12 x 1.75	Ref.- No.:	Steel	Brass	SST303	SST316L
L1	L2	SW				
17	6	17mm HEX ●	4101715		4121715	

GW	M 14 x 1.5	Ref.- No.:	Steel	Brass	SST303	SST316L
L1	L2	SW				
17	6	17mm HEX ●	4101717		4121716	

GW	M 16 x 1.5	Ref.- No.:	Steel	Brass	SST303	SST316L
L1	L2	SW				
18	7	17mm HEX ●	4101719	4111715		

GW	G 1/8, 1/8 - 28 BSPP	Ref.- No.:	Steel	Brass	SST303	SST316L
L1	L2	SW				
17	6	17mm HEX ●	4101761	4111761	4121761	4141761

GW	G 1/4, 1/4 - 19 BSPP	Ref.- No.:	Steel	Brass	SST303	SST316L
L1	L2	SW				
17	6	17mm HEX ●	4101762	4111762	4121762	4141762

GW	G 3/8, 3/8 - 19 BSPP	Ref.- No.:	Steel	Brass	SST303	SST316L
L1	L2	SW				
18	7	17mm HEX ●	4101763	4111763	4121763	4141763

GW	1/4" - 18 NPT/PTF	Ref.- No.:	Steel	Brass	SST303	SST316L
L1	L2	SW				
21	10	17mm HEX ●	4101768			
21.5	11	17mm HEX ●				4141768

Type M22

Button-Head Grease Nipples



- head Ø 22 mm
- according to DIN 3404
- straight version A/180°
- standard versions according to DIN are made of steel, zinc-plated and passivated, with cylindrical thread
- for other types and materials, please see table, or upon request

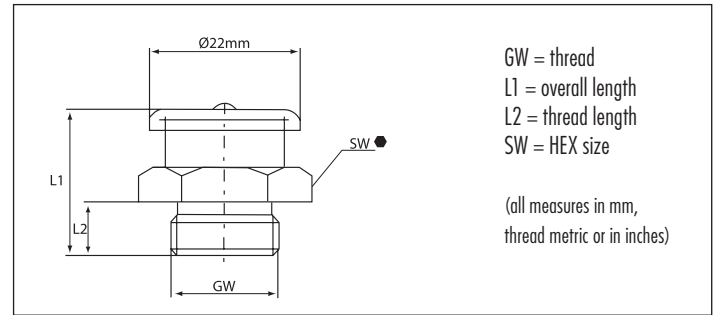

GW	M 10 x 1.0	Ref.- No.:	Steel	Brass	SST303	SST316L
L1	L2	SW				
23.5	9.5	22mm HEX	4302210			

GW	M 16 x 1.5	Ref.- No.:	Steel	Brass	SST303	SST316L
L1	L2	SW				
21.5	8	22mm HEX	4302219	4312219	4322219	

GW	G 1/4, 1/4 - 19 BSPP	Ref.- No.:	Steel	Brass	SST303	SST316L
L1	L2	SW				
21.5	8	22mm HEX	4302262	4312262	4322262	

GW	G 3/8, 3/8 - 19 BSPP	Ref.- No.:	Steel	Brass	SST303	SST316L
L1	L2	SW				
21.5	8	22mm HEX	4302263	4312263	4322263	

GW	G 1/2, 1/2 - 14 BSPP	Ref.- No.:	Steel	Brass	SST303	SST316L
L1	L2	SW				
21.5	8	22mm HEX	4302264			

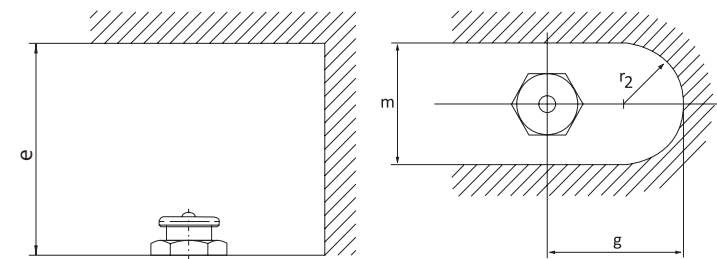

Instructions for installation: necessary space

e =	60 mm/2-3/8"	r =	18 mm/23/32"
m =	36 mm/1-27/64"	g =	45 mm/1-25/32"

Type M22/L

Button-Head Grease Nipples



- head Ø 22 mm
- with extended neck
- according to DIN 3404
- straight version A/180°
- standard versions according to DIN are made of steel, zinc-plated and passivated, with cylindrical thread
- for other types and materials, please see table, or upon request

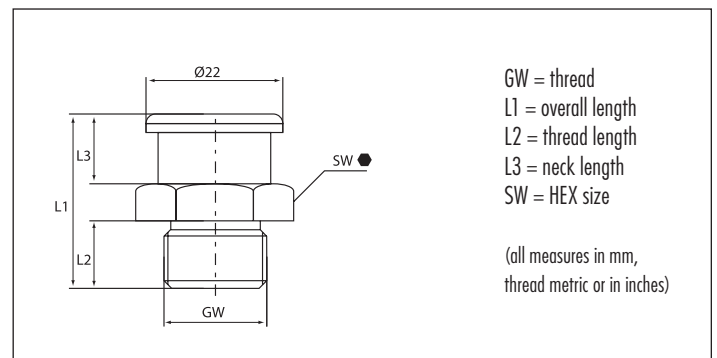

GW	G 1/4, 1/4 - 19 BSPP	Ref.- No.:	Steel	Brass	SST303	SST316L
L1	L2	L3	SW			
28	11.5	11	22mm HEX	4402262		

GW	G 3/8, 3/8 - 19 BSPP	Ref.- No.:	Steel	Brass	SST303	SST316L
L1	L2	L3	SW			
28	11.5	11	22mm HEX	4402263		

GW	G 1/2, 1/2 - 14 BSPP	Ref.- No.:	Steel	Brass	SST303	SST316L
L1	L2	L3	SW			
28	11.5	11	22mm HEX	4402264		

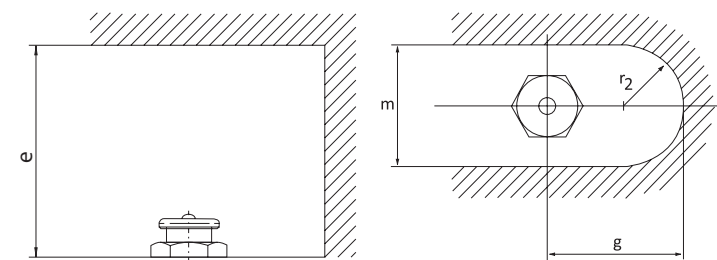

Instructions for installation: necessary space

e =	66 mm/2-39/64"	r =	18 mm/23/32"
m =	36 mm/1-27/64"	g =	45 mm/1-25/32"

Type T1



Button-Head Grease Nipples

- hexagonal head form, Hex size 15 mm
- round collar, Ø 14.5 mm
- straight version A/180°
- standard version made of steel, zinc-plated and passivated, with cylindrical thread
- for other types and materials, please see table, or upon request

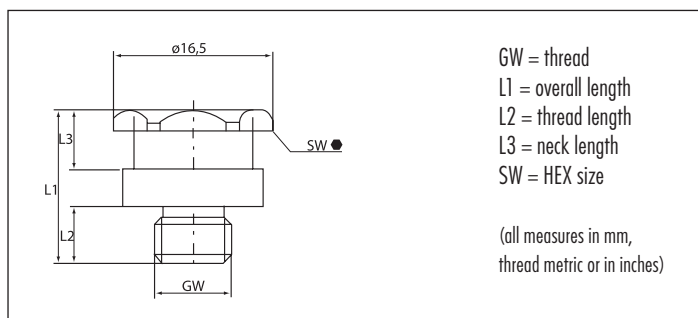

GW	M 6 x 1.0				Ref.- No.:			
L1	L2	L3	SW	Steel	Brass	SST303	SST316L	
16	6	6.2	15mm HEX	4501504				

GW	M 8 x 1.0				Ref.- No.:			
L1	L2	L3	SW	Steel	Brass	SST303	SST316L	
16	6	6.2	15mm HEX	4501507				

GW	M 8 x 1.25				Ref.- No.:			
L1	L2	L3	SW	Steel	Brass	SST303	SST316L	
16	6	6.2	15mm HEX	4501508				

GW	M 10 x 1.0				Ref.- No.:			
L1	L2	L3	SW	Steel	Brass	SST303	SST316L	
16	6	6.2	15mm HEX	4501509				

GW	M 10 x 1.5				Ref.- No.:			
L1	L2	L3	SW	Steel	Brass	SST303	SST316L	
16	6	6.2	15mm HEX	4501511				

GW	G 1/8, 1/8 - 28 BSPP				Ref.- No.:			
L1	L2	L3	SW	Steel	Brass	SST303	SST316L	
16	6	6.2	15mm HEX	4501561	4611560			

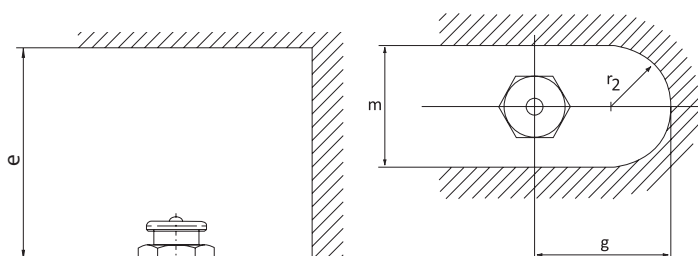

Instructions for installation: necessary space			
e =	55 mm/2-11/64"	r =	16 mm/41/64"
m =	32 mm/1-17/64"	g =	35 mm/1-25/64"

GW	G 1/4, 1/4 - 19 BSPP				Ref.- No.:			
L1	L2	L3	SW	Steel	Brass	SST303	SST316L	
16	6	6.2	15mm HEX	4501562				

GW	1/4" -28 NF/UNF/SAE				Ref.- No.:			
L1	L2	L3	SW	Steel	Brass	SST303	SST316L	
16	6	6.2	15mm HEX	4501537				

Type T1B



Button-Head Grease Nipples

- hexagonal head and collar, Hex size 15 mm
- straight version A/180°
- standard versions according to DIN are made of steel, zinc-plated and passivated, with cylindrical thread
- for other types and materials, please see table, or upon request

GW M 6 x 1.0				Ref.- No.:			
L1	L2	L3	SW	Steel	Brass	SST303	SST316L
16	6	6	15mm HEX	4601504	4611504		

GW M 8 x 1.0				Ref.- No.:			
L1	L2	L3	SW	Steel	Brass	SST303	SST316L
16	6	6	15mm HEX	4601507	4611507		

GW M 8 x 1.25				Ref.- No.:			
L1	L2	L3	SW	Steel	Brass	SST303	SST316L
16	6	6	15mm HEX	4601508	4611508		

GW M 10 x 1.0				Ref.- No.:			
L1	L2	L3	SW	Steel	Brass	SST303	SST316L
16	6	6	15mm HEX	4601509	4611509	4621509	

GW M 10 x 1.5				Ref.- No.:			
L1	L2	L3	SW	Steel	Brass	SST303	SST316L
16	6	6	15mm HEX	4601511	4611511		

GW M 12 x 1.5				Ref.- No.:			
L1	L2	L3	SW	Steel	Brass	SST303	SST316L
16	6	6	15mm HEX	4601514	4611514	4621514	

GW M 12 x 1.75				Ref.- No.:			
L1	L2	L3	SW	Steel	Brass	SST303	SST316L
16	6	6	15mm HEX	4601516			

GW G 1/8, 1/8 - 28 BSPP				Ref.- No.:			
L1	L2	L3	SW	Steel	Brass	SST303	SST316L
16	6	6	15mm HEX	4601561	4611561	4621561	4641561

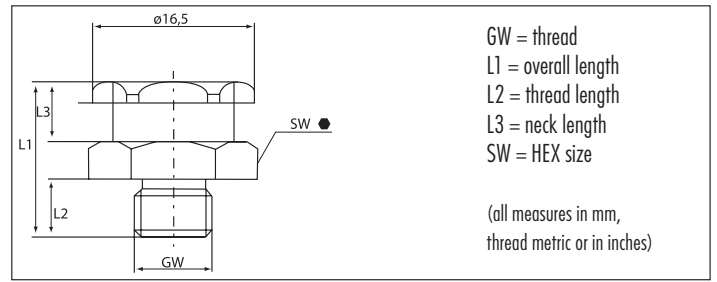

GW = thread
L1 = overall length
L2 = thread length
L3 = neck length
SW = HEX size

(all measures in mm, thread metric or in inches)

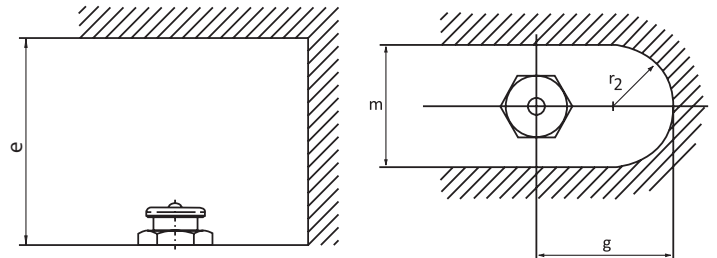

Instructions for installation: necessary space

e =	55 mm/2-11/64"	r =	16 mm/41/64"
m =	32 mm/1-17/64"	g =	35 mm/1-25/64"

GW G 1/4, 1/4 - 19 BSPP				Ref.- No.:			
L1	L2	L3	SW	Steel	Brass	SST303	SST316L
16	6	6	15mm HEX	4601562	4611562	4621562	4641562

GW G 3/8, 3/8 - 19 BSPP				Ref.- No.:			
L1	L2	L3	SW	Steel	Brass	SST303	SST316L
16	6	6	15mm HEX	5372717			

GW 1/8" - 27 NPT/PTF				Ref.- No.:			
L1	L2	L3	SW	Steel	Brass	SST303	SST316L
16	6	6	15mm HEX				4641567

GW 1/4" - 28 NF/UNF/SAE				Ref.- No.:			
L1	L2	L3	SW	Steel	Brass	SST303	SST316L
16	6	6	15mm HEX	4601537			

GW 3/8" - 24 NF/UNF/SAE				Ref.- No.:			
L1	L2	L3	SW	Steel	Brass	SST303	SST316L
16	6	6	15mm HEX	4601539			

■ BUTTON-HEAD GREASE NIPPLES - SPECIAL DESIGNS

The following types are representing only the most commonly used special-type nipples. For individual applications, UMETA manufactures button-head grease nipples with special equipment in other versions, with respect to the following:

- dimension
- material
- thread size
- thread form (e. g. with tapered thread)
- length
- etc.



Button head grease nipple with check valve

Type M1 or Type M22



- Type M1, head-Ø 16 mm or Type M22, head-Ø 22 mm
- straight version A/180°
- made of steel, zinc-plated and passivated, with tapered thread
- as high-pressure version with pin valve upon request

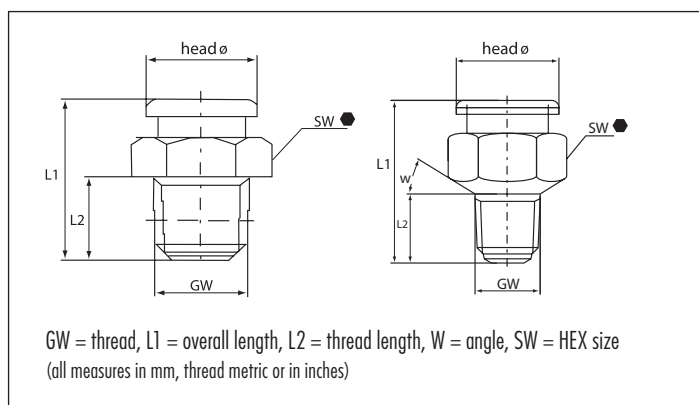

APPLICATION AREA

Due to the special check valve, the lubricating point will be sealed hermetically after the greasing operation. As a result, internal impulse-like pressures up to 1.000 bar (14,500 PSI) can be attained, depending on the respective application. Particularly suitable for the Heavy Industry, Heavy Vehicle Industry.

OPERATING INSTRUCTIONS

ATTENTION! During dismantling, utmost caution is required because of the possible pressure load. Dismantling should be done by experienced personnel only!

GW M 16 x 1.5						Ref.- No.:		
L1	L2	W	Typ	SW		Steel	Brass	SST303
32	12		M 22	22mm HEX ●		5240013		
70	20		M 1	22mm HEX ●		5240020		

GW 1/4" - 18 NPTF						Ref.- No.:		
L1	L2	W	Typ	SW		Steel	Brass	SST303
21	10.7		M 1	17mm HEX ●		5240046		
35	15	30°	M 22	22mm HEX ●		5240061		

GW R 1/4, 1/4 - 19 BSP						Ref.- No.:		
L1	L2	W	Typ	SW		Steel	Brass	SST303
22	11.5		M 1	17mm HEX ●		5376214		

GW 3/8" - 18 NPT/PTF						Ref.- No.:		
L1	L2	W	Typ	SW		Steel	Brass	SST303
33	14	60°	M 22	22mm HEX ●		5240062		

GW G 3/8, 3/8 - 19 BSPP						Ref.- No.:		
L1	L2	W	Typ	SW		Steel	Brass	SST303
23	13		M 1	17mm HEX ●		5376314		
33	13	60°	M 22	22mm HEX ●		5240048		

GW 1/2" - 14 NPT						Ref.- No.:		
L1	L2	W	Typ	SW		Steel	Brass	SST303
29	13		M 22	22mm HEX ●		5240063		
41.5	19	60°	M 22	22mm HEX ●		5240009		

Button-head grease nipple with screwable protection cap

Type M1

- head Ø 16 mm
- straight version A/180°
- with o-ring for sealing against dust and humidity
- with cylindrical thread

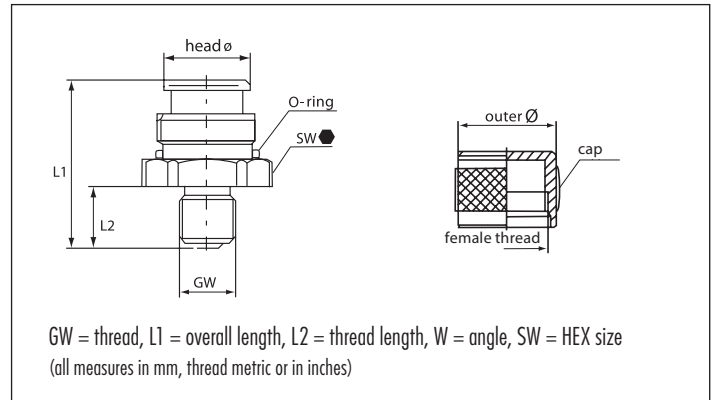

APPLICATION AREA

For additional locking against internal pressure and as protection against contamination. Particularly suitable for plant engineering valves and for exposed lubricating points.

GW	M 10 x 1.0			Ref.- No.:			
L1	L2	SW		Steel	Brass	SST303	SST316L
31	11.5	22mm HEX	●	5544057		5544053	

GW	R 1/4, 1/4 - 19 BSP			Ref.- No.:			
L1	L2	SW		Steel	Brass	SST303	SST316L
31	11.5	22mm HEX	●	5544054			

GW	M 12 x 1.5			Ref.- No.:			
L1	L2	SW		Steel	Brass	SST303	SST316L
31	11.5	22mm HEX	●	5544056			

Button head grease nipple with extension

Type M1



- head Ø 16 mm
- straight version A/180°
- made of steel, zinc-plated and passivated
- head hardened according to DIN with cylindrical thread
- with press-fitted extension for exact grease flow

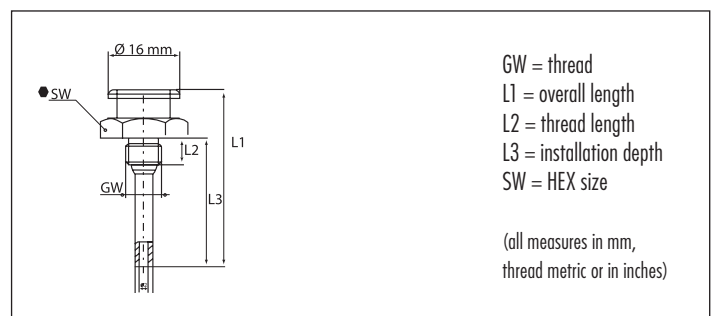

APPLICATION AREA

For deep seated lubrication points, which can be serviced sufficiently through the extension, e. g. for drive shafts.

GW	M 8 x 1.0			Ref.- No.:			
L1	L2	L3	SW	Steel	Brass	SST303	SST316L
40	6	23	17mm HEX	●	5240067		

UMETA BAYONET GREASE NIPPLES

APPLICATION AREA

An especially strong and reliable connection with the grease nipple will be achieved by using the bayonet coupler. The construction design also results in a specific high flow-rate of grease. Particularly suitable for the Heavy Industry, for example Ship Building.

VERSIONS

In general, our bayonet nipples are made of steel, zinc-plated and passivated, and they are featured with a tapered thread. We offer various standard types also in brass or stainless steel 1.4305 ~ ASTM 303 (V2A). Upon request, UMETA manufactures bayonet grease nipples in other versions, with respect to the following:

- dimension
- material
- thread size
- thread form (e. g. with cylindrical thread)
- opening pressure
- etc.



OPERATING INSTRUCTIONS

As suitable lubricating nozzle, we recommend our bayonet coupler.



Type B1

Bayonet Grease Nipples



- head \varnothing 9.9 mm
- straight version A/180°
- standard version made of steel, zinc-plated and passivated, with tapered thread
- for other types and materials, please see table, or upon request

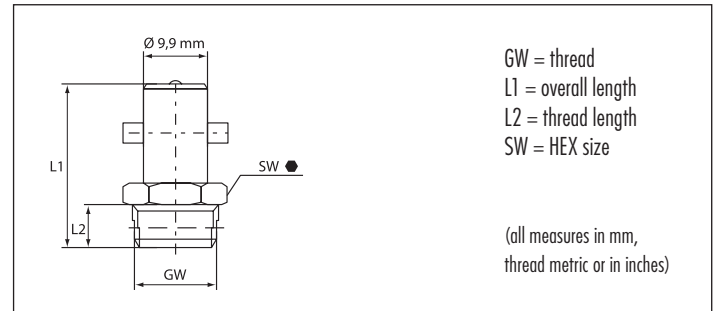

GW	M 16 x 1.5	Ref.- No.:				
L1	L2	SW	Steel	Brass	SST303	SST316L
25	6.5	17mm HEX	9149418			

GW	R 3/8, 3/8 - 19 BSP	Ref.- No.:				
L1	L2	SW	Steel	Brass	SST303	SST316L
25	6.5	17mm HEX	9149417	9157416		

GW	R 1/8, 1/8 - 28 BSP	Ref.- No.:				
L1	L2	SW	Steel	Brass	SST303	SST316L
24	5.5	11mm HEX	9149415	9155416	9157420	

GW	1/8" - 27 NPT/PTF	Ref.- No.:				
L1	L2	SW	Steel	Brass	SST303	SST316L
24	5.5	11mm HEX	9149414			

GW	R 1/4, 1/4 - 19 BSP	Ref.- No.:				
L1	L2	SW	Steel	Brass	SST303	SST316L
25	6.5	14mm HEX	9149416	9156416	9157421	

GW	1/4" - 18 NPT/PTF	Ref.- No.:				
L1	L2	SW	Steel	Brass	SST303	SST316L
25	6.5	14mm HEX			9109416	

UMETA GREASE NIPPLE ASSORTMENTS

UMETA's variety of grease nipple attachments can be trusted to always have the right one available. The kits carry an assortment that should cover all application purposes. In case you require a different assortment, UMETA will be happy to handle this on a case to case basis requiring a minimum order.



Sort 80

Sort 170



Sort 350

Steel, zinc-plated and passivated

consisting of:		Sort 80	Sort 170	Sort 350
Ref.- No.:	UMETA-Type	6008100	6017140	6035140
1100704	H 1, M 6 x 1.0	15	40	50
1100907	H 1, M 8 x 1.0	15	30	40
1101109	H 1, M 10 x 1.0	10	20	35
1101156	H 1, R 1/8"	10	15	30
1101457	H 1, R 1/4"	—	10	15
1204504	H 2, M 6 x 1.0	5	5	25
1204507	H 2, M 8 x 1.0	5	5	20
1204709	H 2, M 10 x 1.0	5	5	15
1204756	H 2, R 1/8"	—	5	15
1201457	H 2, R 1/4"	—	—	10
1304504	H 3, M 6 x 1.0	5	5	20
1304507	H 3, M 8 x 1.0	5	5	15
1304709	H 3, M 10 x 1.0	5	5	15
1304756	H 3, R 1/8"	—	5	15
1301457	H 3, R 1/4"	—	—	15
4101709	M 1, M 10 x 1.0	—	5	5
4101761	M 1, G 1/8"	—	5	—
4101762	M 1, G 1/4"	—	5	—
4302262	M 22, G 1/4"	—	—	5
7351311	515/G, M 10 x 1.0	—	—	2
Total number of pieces		80	170	350

Stainless steel SST303 (V2A)

consisting of:		Sort 80	Sort 170	Sort 350
Ref.- No.:	UMETA-Type	6008102	6017141	upon request
1120704	H 1, M 6 x 1.0	15	40	
1120907	H 1, M 8 x 1.0	15	30	
1121109	H 1, M 10 x 1.0	10	20	
1121156	H 1, R 1/8"	10	15	
1121457	H 1, R 1/4"	—	10	
1220904	H 2, M 6 x 1.0	5	5	
1220907	H 2, M 8 x 1.0	5	5	
1221109	H 2, M 10 x 1.0	5	5	
1221156	H 2, R 1/8"	—	5	
1320904	H 3, M 6 x 1.0	5	5	
1320907	H 3, M 8 x 1.0	5	5	
1321109	H 3, M 10 x 1.0	5	5	
1321156	H 3, R 1/8"	—	5	
4121709	M 1, M 10 x 1.0	—	5	
4121761	M 1, G 1/8"	—	5	
4121762	M 1, G 1/4"	—	5	
Total number of pieces		80	170	

dimension (L x W x H) in cm: Sort 80 = 17.0 x 11,5 x 3.0
 Sort 170 = 21.0 x 13,0 x 3.5
 Sort 350 = 25.0 x 18,0 x 4.5





UMETA ACCESSORIES FOR GREASE NIPPLES





UMETA Plastic Protection Caps



- suitable for grease nipples with hydraulic head according to DIN 71412
- suitable for a temperatur of approx. - 70°C up to + 85°C

The protection caps are available with or without straps and in various colours. They are used for protecting the lubricating point against contamination and for indicating the lubricating intervals by colour coding.

Type	Ref.- No.:
SK-R 	9500110
SK-RL 	9500111
SK-V 	9500120
SK-VL 	9500121

Type	Ref.- No.:
SK-G 	9500130
SK-GL 	9500131
SK-B 	9500140
SK-BL 	9500141



UMETA Rubber Protection Caps

- suitable for grease nipples with button head M1 according to DIN 3404

suitable for grease nipples with	Ref.- No.:
button head M1 according to DIN 3404	9500210



UMETA Alu Protection Caps

- suitable for grease nipples with hydraulic-type or button-head according to DIN 71412 and DIN 3404
- suitable for a temperatur of - 30°C up to + 120°C

For an especially easy clip-on and take-off. Optionally our aluminium protection caps can be anodised in colours for indicating the lubricating intervals.

suitable for grease nipples with	Ref.- No.:
hydraulic head according to DIN 71412	9500200
button head M1 according to DIN 3404	9500201

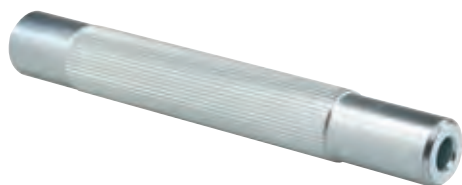

UMETA Drive-in Tool

- for safe drive-in of straight drive-in or serrated ridge nipples

suitable for grease nipples with	Ref.- No.:
ball-type or hydraulic head according to DIN	5800058
ball-type or hydraulic head according to SAE	5800059



UMETA GREASE FITTINGS ACCORDING TO SAE J-534

VERSIONS

In general, our grease fittings according to SAE are made of steel, case hardened, zinc-plated, passivated and featured with a special surface treatment. For safety reasons and in order to avoid abrasion wear, the standard for SAE-grease fittings demands a specific surface hardness of 83 HR15 N minimum according to Rockwell hardness test procedure.

SPECIAL INFORMATION

For a better overview we added the international Alemite-reference numbers to our grease fittings. A general comparison of the relevant types you will find on page 78.

UMETA HYDRAULIC-TYPE GREASE FITTINGS ACCORDING TO SAE J-534

The SAE-standard for hydraulic-type grease fittings requires a tapered thread. The standard head-Ø is 6.6 (+/- 0.3) mm / 0.26" (+/- 0.012").



OPERATING INSTRUCTIONS

As suitable lubricating nozzle for our hydraulic-type fittings, we recommend our hydraulic couplers.

Type H1



Hydraulic-Type Grease Fittings

- according to SAE J-534
- straight version A/180°
- standard versions according to SAE are made of steel, hardened, zinc plated, passivated and top coated
- salt spray resistance > 72 hours

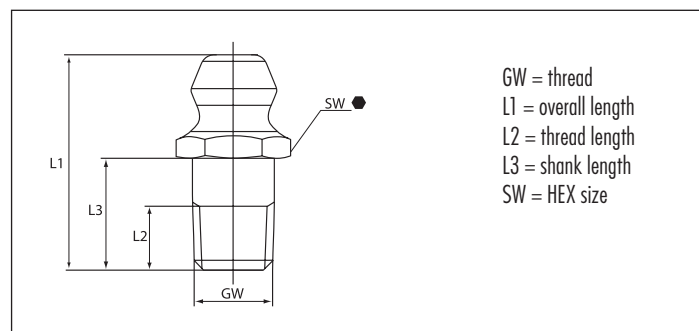

GW 1/8" PTF				Ref.- No.:		
L1	L2	L3	SW	Steel	SST303	Alemite
11/16"	5/32"	19/64"	7/16"HEX	5546006		1610-BL
9/16"	5/32"	15/64"	7/16"HEX	5546008		1644-B
1 1/4"	5/16"	25/32"	7/16"HEX	5546010		1607-B
1 3/4"	5/16"	1 17/64"	7/16"HEX	5546012		1669-B
2 5/8"	5/16"	2 3/16"	3/8"HEX	5546014		1684-B
3/4"	3/16"	5/16"	7/16"HEX		5546086	1961-S
1"	9/32"	5/16"	1/2"HEX	*1) 5546016		1618-B

GW 1/4" - 28 UNF-2A				Ref.- No.:		
L1	L2	L3	SW	Steel	SST303	Alemite
33/64"	5/64"	5/32"	9/32"HEX	5546106		1792-B

GW 3/8" - 18 NPTF				Ref.- No.:		
L1	L2	L3	SW	Steel	SST303	Alemite
20 mm	8 mm		17 mm HEX	*2) 5547001		

GW 1/4" PTF				Ref.- No.:		
L1	L2	L3	SW	Steel	SST303	Alemite
7/8"	15/64"	27/64"	9/16"HEX	5546028		1627-B
7/8"	25/64"	27/64"	15 mm HEX		5546154	-

GW 6/40" UNF-2A				Ref.- No.:		
L1	L2	L3	SW	Steel	SST303	Alemite
1/2"	7/64"	1/8"	1/4"HEX	*3) 5546507		3018

GW 1/4" - 28 SAE-LT				Ref.- No.:		
L1	L2	L3	SW	Steel	SST303	Alemite
35/64"	7/64"	3/16"	5/16"HEX	5546030		1641-B
11/16"	13/64"	23/64"	5/16"HEX	5546032		1652-B
31/32"	13/64"	5/8"	5/16"HEX	5546034		1680-B
1 1/8"	13/64"	25/32"	5/16"HEX	5546036		1698-B
1 5/8"	13/64"	1 9/32"	5/16"HEX	5546038		3014-B
17/32"	7/64"	3/16"	5/16"HEX		5546087	1966-S

GW 10/32" UNF-2A				Ref.- No.:		
L1	L2	L3	SW	Steel	SST303	Alemite
1/2"	7/64"	1/8"	1/4"HEX	*3) 5546503		3016

Type H1 Hydraulic-Type Grease Fitting with pin valve, leakproof

GW 1/8" PTF				Ref.- No.:		
L1	L2	L3	SW	Steel	SST303	Alemite
3/4"	17/64"	5/16"	7/16"HEX	5546110		1650

*1) female thread
*2) molybdenum-surface finish
*3) no ball check



Type H2



Hydraulic-Type Grease Fittings

- according to SAE J-534
- elbow version B - 30°/45°/65°/67°
- optionally available with square or hexagonal body
- standard versions according to SAE are made of steel, zinc-plated, passivated and top coated, head hardened
- salt spray resistance > 72 hours

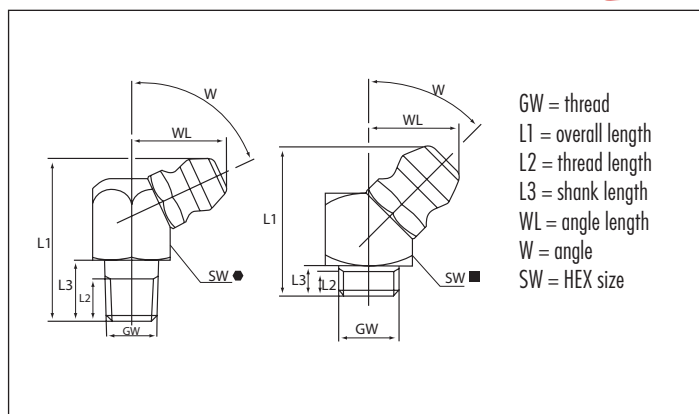

GW 1/8" PTF							Ref.- No.:		
L1	L2	L3	WL	W	SW	Steel	SST303	Alemite	
29/32"	19/64"	19/64"	11/32"	30°	7/16" HEX ●	5546152		1611-B	
29/32"	19/64"	19/64"	11/32"	30°	7/16" HEX ●		5546153	1921-S	
57/64"	3/16"	19/64"	29/64"	45°	7/16" HEX ●	5546017		1688-B	
27/32"	3/16"	19/64"	1/2"	65°	7/16" HEX ●	5546018		1612-B	
1 7/32"	3/16"	9/16"	1/2"	65°	7/16" HEX ●	5546020		1623-B	
2 3/4"	11/32"	2 1/4"	1/2"	65°	3/8" HEX ●	5546022		1649-B	
61/64"	7/32"	11/32"	1/2"	67°	7/16" HEX ●		5546090	1922-S	

GW 1/4" - 28 SAE-LT							Ref.- No.:		
L1	L2	L3	WL	W	SW	Steel	SST303	Alemite	
13/16"	7/64"	13/64"	13/32"	45°	3/8" HEX ●	5546040		1637-B1	
25/32"	13/64"	19/64"	15/32"	65°	3/8" HEX ●	5546042		3010-B1	
13/16"	13/64"	13/64"	19/32"	45°	3/8" HEX ●		5546085	1968-S	

GW 1/4" - 28 UNF-2A							Ref.- No.:		
L1	L2	L3	WL	W	SW	Steel	SST303	Alemite	
39/64"	5/64"	1/8"	13/32"	45°	*9 mm SQ ■	5546108		1770-B1	

Type H3



Hydraulic-Type Grease Fittings

- according to SAE J-534
- elbow version C/90°
- standard versions according to SAE are made of steel, zinc-plated, passivated and top coated, head hardened
- salt spray resistance > 72 hours

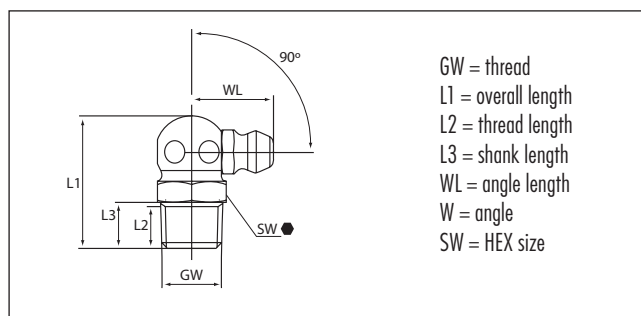

GW 1/8" PTF							Ref.- No.:		
L1	L2	L3	WL	W	SW	Steel	SST303	Alemite	
27/32"	3/16"	19/64"	17/32"	90°	7/16" HEX ●	5546024		1613-B	
1 13/16"	5/16"	1 1/4"	17/32"	90°	7/16" HEX ●	5546026		1606-B	
7/8"	7/32"	11/32"	17/32"	90°	7/16" HEX ●		5546088	1923-S	

GW 1/4" - 28 SAE-LT							Ref.- No.:		
L1	L2	L3	WL	W	SW	Steel	SST303	Alemite	
3/4"	7/64"	13/64"	1/2"	90°	3/8" HEX ●	5546044		1911-B1	
3/4"	7/64"	13/64"	1/2"	90°	3/8" HEX ●		5546089	1969-S	

*cylindrical



HYDRAULIC GREASE FITTINGS WITH SELF-FORMING THREAD ACCORDING TO SAE J-534

VERSIONS

For safety reasons and in order to avoid abrasion wear, the standard for SAE-grease fittings demands a specific surface hardness of 83 HR15 N minimum according to Rockwell hardness test procedure. Furthermore, a particularly wide flank angle of 90° at the thread is stipulated therein. For a better visual distinction, UMETA self-forming grease fittings are yellow passivated. Upon request, they are also available in another surface colour, e. g. blue passivated = silver coloured.

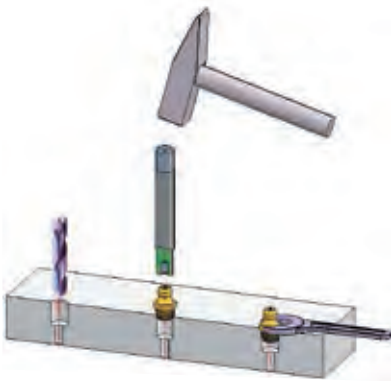

Type H1/S

Hydraulic-Type Grease Fittings with Self-Forming Thread



- according to SAE J-534
- straight version A/180°
- with self-forming thread, tapered
- standard version made of steel, according to SAE hardened, yellow passivated and top coated
- salt spray resistance > 72 hours

SFG 1/8" Special Taper Pipe Thread						Ref.- No.:	
L1	L2	for bore-Ø	SW	Steel	Alemite		
5/8"	15/16"	0.373-0.380"	7/16" HEX	5546052	1720-B		

Type H2/S

Hydraulic-Type Grease Fittings with Self-Forming Thread



- according to SAE J-534
- elbow version B - 45°/65°
- with self-forming thread, tapered
- standard version made of steel, according to SAE hardened, yellow passivated and top coated
- salt spray resistance > 72 hours

SFG 1/8" Special Taper Pipe Thread							Ref.- No.:	
L1	L2	WL	W	for bore-Ø	SW	Steel	Alemite	
3/4"	13/64"	1/2"	65°	0.373-0.380"	7/16" HEX	5546054	1722-B	

MOUNTING INSTRUCTIONS

The exact size of the core hole depends on the material and must be determined by mounting tests. The consistency of the receiving material is decisive. The standard gauge for the installation bore diameter of 0.4-0.5 mm (0.02") below nominal width have proved in daily use. The recommended borehole Ø is listed with the part number.

OPERATING INSTRUCTIONS

As suitable lubricating nozzle, we recommend our hydraulic couplers.

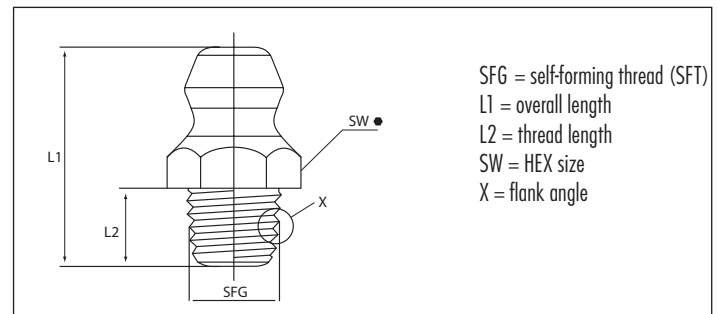
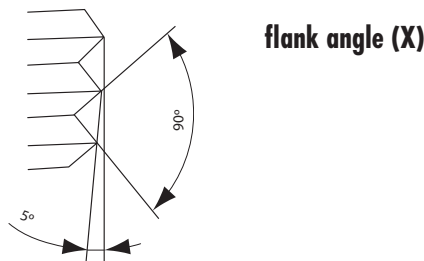

SFG 1/4" - 28 Special Taper Thread						Ref.- No.:	
L1	L2	for bore-Ø	SW	Steel	Alemite		
37/64"	13/64"	0.230"-0.235"	5/16" HEX	5546046	3038-B		

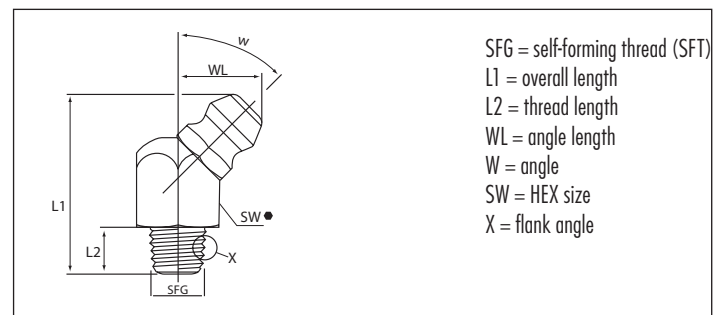

SFG 1/4" - 28 Special Taper Thread							Ref.- No.:	
L1	L2	WL	W	for bore-Ø	SW	Steel	Alemite	
13/16"	13/64"	25/64"	45°	0.230"-0.235"	3/8" HEX	5546048	3053-B	



Type H3/S



Hydraulic-Type Grease Fittings with Self-Forming Thread

- according to SAE J-534
- elbow version C/90°
- with self-forming thread, tapered
- standard version made of steel, according to SAE hardened, yellow passivated and top coated
- salt spray resistance > 72 hours

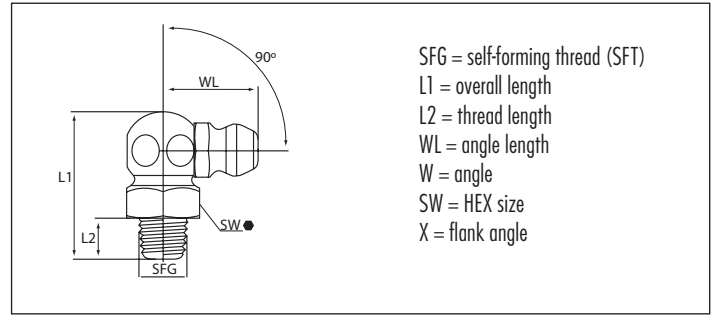

SFG 1/8" Special Taper Pipe Thread							Ref.- No.:	
L1	L2	WL	W	for bore-Ø	SW	Steel	Alemite	
49/64"	13/64"	17/32"	90°	0.373-0.380"	7/16" HEX	5546056	1723-B	

SFG 1/4" - 28 Special Taper Thread							Ref.- No.:	
L1	L2	WL	W	for bore-Ø	SW	Steel	Alemite	
3/4"	13/64"	1/2"	90°	0.230"-0.235"	3/8" HEX	5546050	3054-B	

UMETA HYDRAULIC-TYPE GREASE FITTINGS - DRIVE-IN VERSION (USA VERSION)

VERSIONS

Drive-in fittings as standard version are made of steel, case-hardened, zinc-plated, passivated and top coated.

MOUNTING INSTRUCTIONS

The exact size of the core hole depends on the material and must be determined by mounting tests. The standard gauge for the installation bore diameter corresponds to the nominal width of the serrated ridge-Ø.

OPERATING INSTRUCTIONS

Since this type of grease fitting is only driven in, it may get loose by

- strong vibrations
- high back-pressure when greasing with automatic guns
- pulling off the hydraulic coupler.

Drive-in type hydraulic grease fittings should only be lubricated by a hydraulic nozzle.

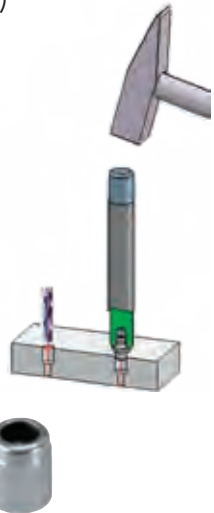

Type H1a



Hydraulic-Type Grease Fittings - Drive-in Type

- straight version A/180°
- with serrated ridge
- standard version made of steel, according to SAE hardened, zinc plated, passivated and top coated
- salt spray resistance > 72 hours

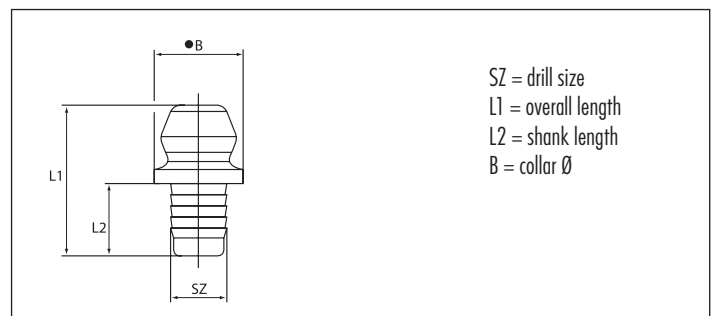

SZ 3/16"					Ref.- No.:	
L1	L2	SZ	B	Steel	Alemite	
15/32"	11/64"	3/16"	5/16" Ø	*5546060	3005	
31/64"	7/32"	3/16"	9/32" Ø	*5546062	3006	
33/64"	1/4"	3/16"	5/16" Ø	5546064	1728-B	
5/8"	1/4"	3/16"	5/16" Ø	*5546066	1633	

SZ 5/16"				Ref.- No.:	
L1	L2	SZ	B	Steel	Alemite
35/64"	1/4"	5/16"	3/8" Ø	5546074	1608-B
5/8"	7/32"	5/16"	3/8" Ø	*5546076	1699

SZ 1/4"					Ref.- No.:	
L1	L2	SZ	B	Steel	Alemite	
35/64"	1/4"	1/4"	11/32" Ø	5546068	1743-B	
9/16"	17/64"	1/4"	11/32" Ø	*5546070	321381	
15/32"	1/8"	1/4"	11/32" Ø	*5546072	1952	

SZ 6.35 mm, 1/4" Ø				Ref.- No.:	
L1	L2	SZ	B	Steel	Alemite
15 mm	6.3 mm	6.35 mm, 1/4" Ø	8 mm Ø	5241043	

SZ 3/8"				Ref.- No.:	
L1	L2	SZ	B	Steel	Alemite
37/64"	7/32"	3/8"	7/16" Ø	*5546078	1666

*no ball check



Type H2a



Hydraulic-Type Grease Fittings - Drive-in Type

- elbow version B/45°/67°
- with serrated ridge
- standard version made of steel, according to SAE zinc plated, passivated and top coated, head hardened
- salt spray resistance > 72 hours

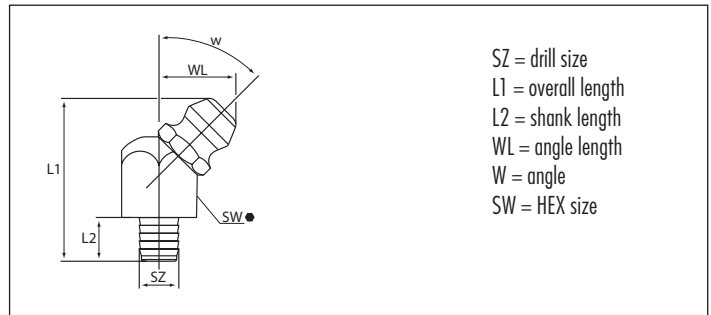

SZ = drill size
L1 = overall length
L2 = shank length
WL = angle length
W = angle
SW = HEX size

SZ 3/16"

Ref.- No.:

L1	L2	WL	W	SZ	SW	Steel	Alemite
53/64"	7/32"	13/32"	45°	3/16"	3/8" HEX	5546080	1992-B1
45/64"	7/32"	1/2"	65°	3/16"	3/8" HEX	5546082	1646-B1



Hydraulic-Type Grease Fittings - Rivet Type

- designed for mounting on the back side of thin-walled sheet metal
- standard version made of steel, according to SAE hardened, zinc plated, passivated and top coated
- salt spray resistance > 72 hours

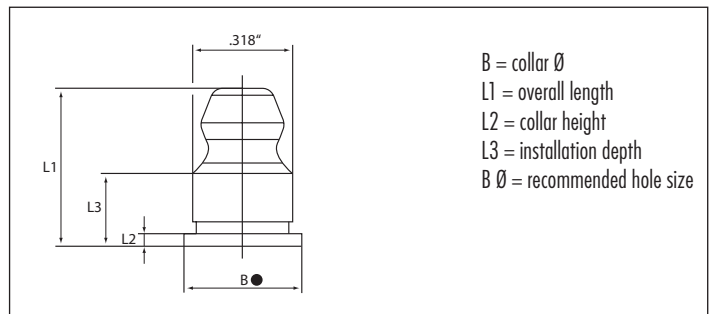

B = collar Ø
L1 = overall length
L2 = collar height
L3 = installation depth
B Ø = recommended hole size

B Ø 5/16"

Ref.- No.:

L1	L2	L3	for bore Ø	B	Steel	Alemite
1/2"	5/128"	15/64"	5/16"	3/8" Ø	5546122	1675-B

UMETA FLUSH-TYPE GREASE FITTINGS (USA VERSION)

Type D1



Flush-Type Grease Fittings

- straight version A/180°
- made of steel, zinc plated, passivated and top coated
- salt spray resistance > 72 hours

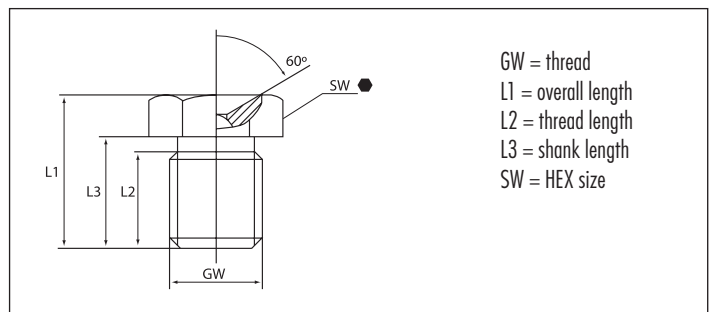

GW = thread
L1 = overall length
L2 = thread length
L3 = shank length
SW = HEX size

GW 1/4" - 28 NF

Ref.- No.:

L1	L2	L3	SW	Steel	Alemite
13/32"	3/16"	19/64"	5/16" HEX	5546130	1851



Type DV1

Flush-Type Grease Fittings



- without collar, with slot for screwdriver
- for even mounting without projection
- straight version A/180°
- made of steel, zinc-plated, passivated and top coated
- salt spray resistance > 72 hours

GW 1/8" NPTF		Ref.- No.:	
L1	L2	Steel	Alemite
23/64"	19/64"	5546124	1815
17/32"		5546126	1452

GW 1/4" NPTF		Ref.- No.:	
L1	L2	Steel	Alemite
9/16"		5546128	2741-A

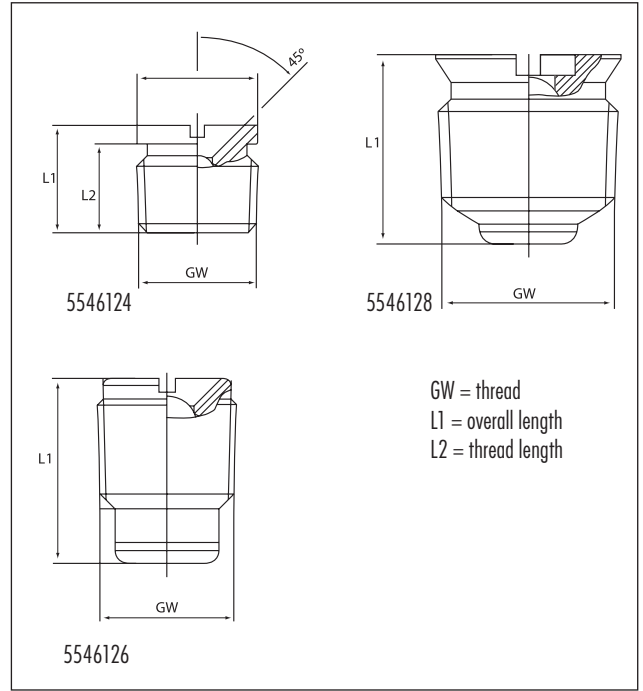

UMETA BUTTON-HEAD GREASE FITTINGS ACCORDING TO SAE J-534

Type M1

Button-Head Grease Fittings



- head Ø 15.5 mm (5/8")
- according to SAE J-534
- straight version A/180°
- standard versions according to SAE are made of steel, hardened, zinc plated, passivated and top coated
- salt spray resistance > 72 hours

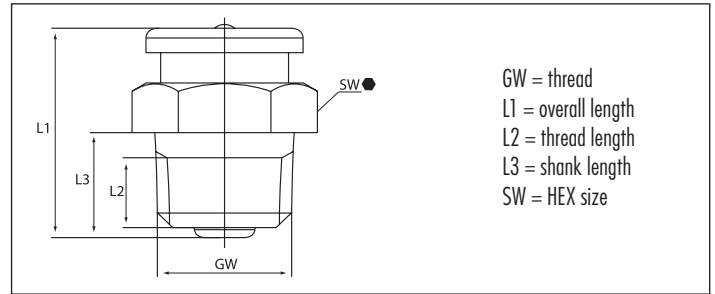

GW 1/8" PTF				Ref.- No.:		
L1	L2	L3	SW	Steel	SST303	Alemite
3/4"	3/16"	11/32"	5/8" HEX ●	5546112		1184-B

GW 1/4" NPTF				Ref.- No.:		
L1	L2	L3	SW	Steel	SST303	Alemite
53/64"	17/64"	27/64"	5/8" HEX ●	*5546114		A1186
53/64"	17/64"	27/64"	5/8" HEX ●	5546116		1186-B

Type M1 according to ISO 2768-m - stainless steel

Button-Head Grease Fittings

- head Ø 15.5 mm (5/8")
- according to ISO 2768 - m
- straight version A/180°
- made of stainless steel 1.4305 ~ ASTM 303 (V2A)

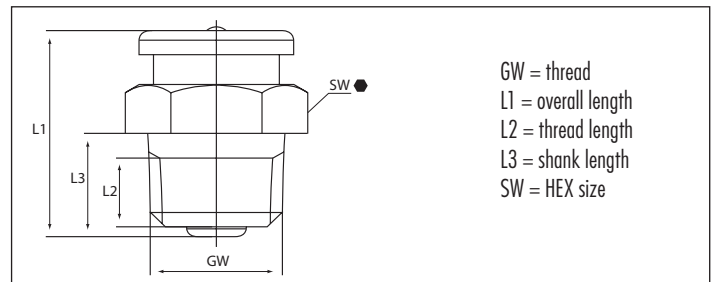

GW 1/8" PTF				Ref.- No.:		
L1	L2	L3	SW	Steel	SST303	Alemite
18 mm	4.8 mm	7.5 mm	17 mm HEX ●	5547020		-

GW 3/8" NPTF				Ref.- No.:		
L1	L2	L3	SW	Steel	SST303	Alemite
23.5 mm	13 mm	13 mm	19 mm HEX ●	5547022		-

GW 1/4" - 18 NPTF				Ref.- No.:		
L1	L2	L3	SW	Steel	SST303	Alemite
21 mm	6.75 mm	10.7 mm	17 mm HEX ●	5547021		-

*with plunger check



Type M22



UMeta Button-Head Grease Fittings with plunger check

- head Ø 21.9 mm (7/8")
- according to SAE J-534
- straight version A/180°
- standard versions according to SAE are made of steel, hardened, zinc plated, passivated and top coated
- salt spray resistance > 72 hours

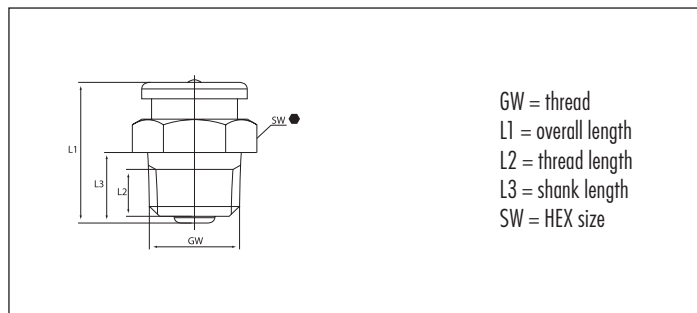

GW 1/2" N.PTF				Ref.- No.:		
L1	L2	L3	SW	Steel	SST303	Alemite
1 1/6"	25/64"	1/2"	7/8" HEX	●	*5546120	1820-1

*with plunger check

UMETA ADAPTER (USA VERSION)

Adapters / elbow bodies



- elbow version 180°/45°/90°
- optionally available with square or hexagonal body
- standard version made of steel, according to SAE zinc plated, passivated and top coated
- salt spray resistance > 72 hours

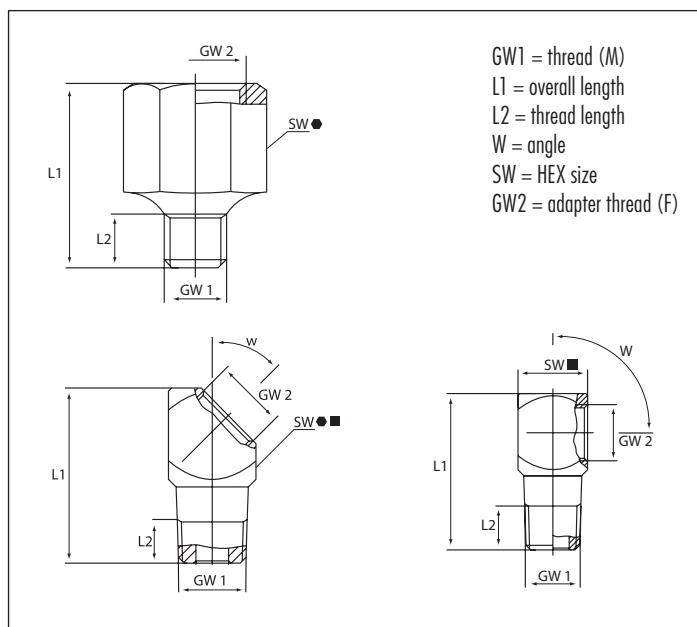

GW1 (M) 1/8" - 27 NPT/PTF				Ref.- No.:		
L1	L2	W	GW2 (F)	SW	Steel	Alemite
1"	7/32"	45°	1/8" - 27 NPT/PTF	1/2" SQ	■	5546134 43716
1 1/8"	17/64"	90°	1/8" - 27 NPT/PTF	1/2" SQ	■	5546132 43706

GW1 (M) 1/4" - 28 NF/UNF/SAE				Ref.- No.:		
L1	L2	W	GW2 (F)	SW	Steel	Alemite
3/4"	13/64"	180°	1/8"-NPTF	1/2" HEX	●	5546135 51942
13/16"	13/64"	45°	1/8"-NPTF	1/2" HEX	●	5546157 310912
1 1/32"	7/32"	90°	1/8"-NPTF	1/2" SQ	■	5546159 51943

UMETA GREASE FITTING ASSORTMENTS ACCORDING TO SAE J-534

UMETA's grease fitting assortments ensure you always have the right one available. The kits carry an assortment that should cover all application purposes.

Sort 110



- standard version according to SAE, made of steel, hardened, zinc plated, passivated and top coated
- salt spray resistance > 72 hours

Sort 110 consisting of:			6110100
Ref.- No.:	UMETA-Type	Alemite-Type	Quantity
5546006	H1, 1/8" PTF, 11/16"	1610-BL	25
5546040	H2, 1/4" - 28 SAE-LT, 13/16"	1637-B1	15
5546024	H3, 1/8" PTF, 27/32"	1613-B	15
5546030	H1, 1/4" - 28 SAE-LT, 35/64"	1641-B	25
5546017	H2, 1/8" PTF, 57/64"	1688-B	15
5546044	H3, 1/4" - 28 SAE-LT, 3/4"	1911-B1	15
Total number of pieces			110



UMETA TURNED PARTS ACCORDING TO SAE J-534

Plugs



- according to SAE J-534
- for subsequent closing of boreholes
- made of steel, zinc-plated, passivated and top coated
- salt spray resistance > 72 hours

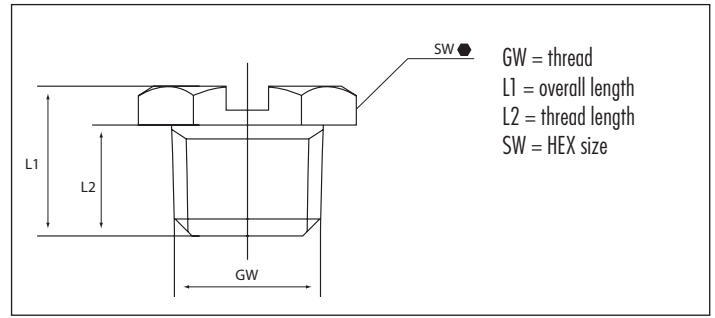

GW		1/4" - 28 UNF-2A		Ref.- No.:	
L1	L2	Thread	Steel	Alemite	
1/4"	3/16"	5/16" HEX	5546138	328224	

Plugs with Self-Forming Thread



- according to SAE J-534
- with self-forming thread, tapered
- standard version made of steel, hardened according to SAE (650HV) and yellow passivated
- salt spray resistance > 72 hours
- recommended hole size = 0.02" below nominal width

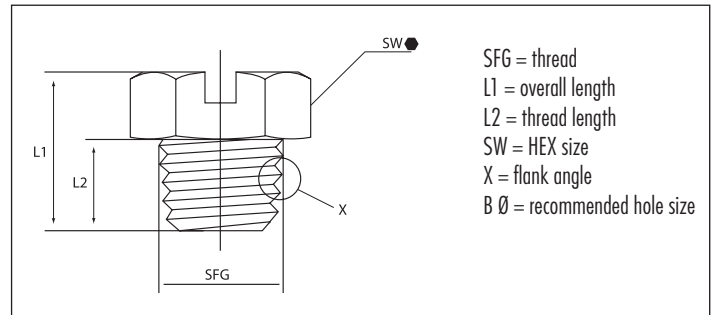

SFG		1/4" - 28 Special Taper Thread		Ref.- No.:	
L1	L2	for bore-Ø	SW	Steel	Alemite
21/64"	3/16"	0.230"-0.235"	5/16" HEX	5546140	328435

International Reference Chart

Ref.- No.:	Page	Ref.- No.:	Page	Ref.- No.:	Page	Ref.- No.:	Page		
UMETA	Alemite	UMETA	Alemite	UMETA	Alemite	UMETA	Alemite		
5241043	74	5546052	1720-B 73	5546120	1820-1 77	1618-B	5546016 71	1961-S	5546086 71
5546006	1610-BL 71	5546054	1722-B 73	5546122	1675-B 75	1623-B	5546020 72	1966-S	5546087 71
5546008	1644-B 71	5546056	1723-B 74	5546124	1815 76	1627-B	5546028 71	1968-S	5546085 72
5546010	1607-B 71	5546060	3005 74	5546126	1452 76	1637-B1	5546040 72	1969-S	5546089 72
5546012	1669-B 71	5546062	3006 74	5546128	2741-A 76	1641-B	5546030 71	1992-B1	5546080 75
5546014	1684-B 71	5546064	1728-B 74	5546130	1851 75	1644-B	5546008 71	3010-B1	5546042 72
5546016	1618-B 71	5546066	1633 74	5546132	43706 77	1646-B1	5546082 75	3014-B	5546038 71
5546017	1688-B 72	5546068	1743-B 74	5546134	43716 77	1649-B	5546022 72	3038-B	5546046 73
5546018	1612-B 72	5546070	321381 74	5546135	51942 77	1652-B	5546032 71	3053-B	5546048 73
5546020	1623-B 72	5546072	1952 74	5546138	328224 78	1669-B	5546012 71	3054-B	5546050 74
5546022	1649-B 72	5546074	1608-B 74	5546140	328435 78	1675-B	5546122 75	A1186	5546114 76
5546024	1613-B 72	5546076	1699 74	5546152	1611-B 72	1680-B	5546034 71	2741-A	5546128 76
5546026	1606-B 72	5546078	1666 74	5546153	1921-S 72	1684-B	5546014 71	310912	5546157 77
5546028	1627-B 71	5546080	1992-B1 75	5546154	71	1688-B	5546017 72	321381	5546070 74
5546030	1641-B 71	5546082	1646-B1 75	5546157	310912 77	1698-B	5546036 71	328224	5546138 78
5546032	1652-B 71	5546085	1968-S 72	5546159	51943 77	1720-B	5546052 73	328435	5546140 78
5546034	1680-B 71	5546086	1961-S 71	5546503	3016 71	1722-B	5546054 73		5241043 74
5546036	1698-B 71	5546087	1966-S 71	5546507	3018 71	1723-B	5546056 74		5546154 71
5546038	3014-B 71	5546088	1923-S 72	5547001	71	1728-B	5546064 74		5547001 71
5546040	1637-B1 72	5546089	1969-S 72	5547020	76	1743-B	5546068 74		5547020 76
5546042	3010-B1 72	5546090	1922-S 72	5547021	76	1770-B1	5546108 72		5547021 76
5546044	1911-B1 72	5546092	1792-S 71	5547022	76	1792-B	5546106 71		5547022 76
5546046	3038-B 73	5546106	1792-B 71	6110100	77	1820-1	5546120 77		6110100 77
5546048	3053-B 73	5546108	1770-B1 72			1820-1	5546120 77		
5546050	3054-B 74	5546110	1650 71			1610-BL	5546006 71		
		5546112	1184-B 76			1611-B	5546152 72		
		5546114	A1186 76			1612-B	5546018 72		
		5546116	1186-B 76			1613-B	5546024 72		
						1452	5546126 76		
						1633	5546066 74		
						1650	5546110 71		
						1666	5546078 74		
						1699	5546076 74		
						1815	5546124 76		
						1851	5546130 75		
						1952	5546072 74		
						3005	5546060 74		
						3006	5546062 74		
						3016	5546503 71		
						3018	5546507 71		
						43706	5546132 77		
						43716	5546134 77		
						51942	5546135 77		
						51943	5546159 77		
						1184-B	5546112 76		
						1186-B	5546116 76		
						1606-B	5546026 72		
						1607-B	5546010 71		
						1608-B	5546074 74		
						1610-BL	5546006 71		
						1611-B	5546152 72		
						1612-B	5546018 72		
						1613-B	5546024 72		
						1618-B	5546016 71		
						1623-B	5546020 72		
						1627-B	5546028 71		
						1637-B1	5546040 72		
						1641-B	5546030 71		
						1644-B	5546008 71		
						1646-B1	5546082 75		
						1649-B	5546022 72		
						1652-B	5546032 71		
						1669-B	5546012 71		
						1675-B	5546122 75		
						1680-B	5546034 71		
						1684-B	5546014 71		
						1688-B	5546017 72		
						1698-B	5546036 71		
						1720-B	5546052 73		
						1722-B	5546054 73		
						1723-B	5546056 74		
						1728-B	5546064 74		
						1743-B	5546068 74		
						1770-B1	5546108 72		
						1792-B	5546106 71		
						1820-1	5546120 77		
						1911-B1	5546044 72		
						1921-S	5546153 72		
						1922-S	5546090 72		
						1923-S	5546088 72		

TURNED PARTS

From prototype to series production-readiness!

Umeta is the right partner for you and your turned parts projects. We support you from the very first development stage through initial sampling right up to series production-readiness.

Manufacturing special turned parts is one of our strengths, whether in small or large series. Our machinery consists of long CNC-controlled lathes and capstan lathes. We also provide assembly services and the manufacture of complete component groups as an option.

This means we can offer complex machining facilities.

You will find locking plugs and air release valves in the standard programme of our turned parts division, and we would like to show you a few samples of further production facilities below.



UMETA TURNED PARTS AT A GLANCE

- production batches from 1 piece
- raw material measurements from \varnothing 3 mm to \varnothing 42 mm
- turning lengths up to 600 mm
- machining of all removable materials
- high-precision production of complex contours (tolerance ranges of 0.02 mm and a surface roughness Rz of 1.0 μ m are possible)
- axial and radial milling / drilling with lathing of bars
- eccentric drilling with axial machining
- extensive machining of front and back sides with lathing of bars
- changes in machining contours can be realised quickly and economically by programming the parameters

EXAMPLES OF MACHINING FACILITIES

chain tensioner

(machining of front, back, air release groove)

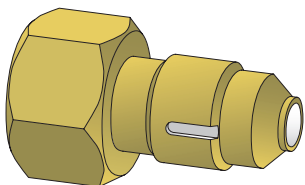

bayonet top

(radial milling of shell)

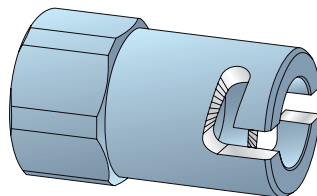

clamping hydraulic body

(radial two-step drilling/apply to spanner flat)

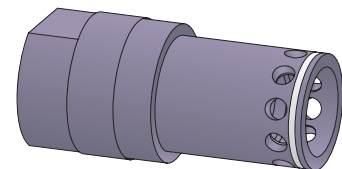

injection nozzle

(axial/radial machining, long turned parts, assembling)

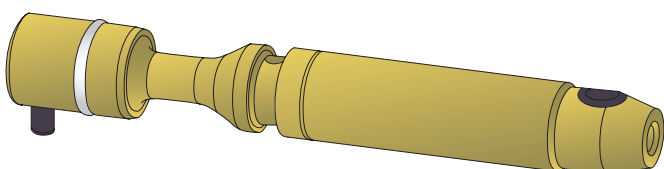

AIR BLEED VALVES

The standard air bleed valves for venting and avoidance of undesirable pressure increases are zinc-plated and passivated, and they are featured with a tapered thread. The following types are representing a selection of the most commonly used air bleed valves.

Upon request, UMETA manufactures air bleed valves in other versions, with respect to the following:

- opening pressure
- dimension
- material
- thread size
- thread form (e. g. with cylindrical thread)
- further surface treatment
- etc.



Air bleed valves



- for venting gears
- for the avoidance of undesirable pressure increases in universal joints
- made of steel, zinc-plated and passivated, with tapered thread
- for other types and materials, please see table, or upon request

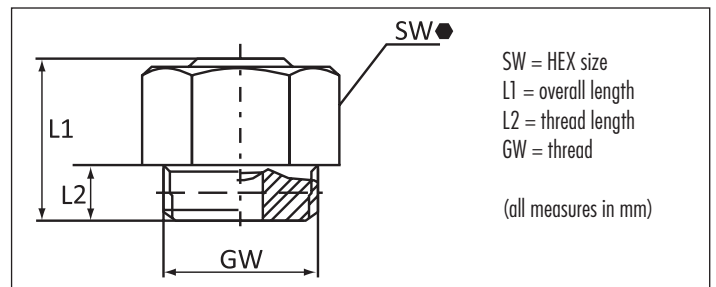

GW		M 6 x 1.0		Ref.- No.:	
L1	L2	SW	Opening pressure	Steel	SST303 SST316L
11	7	7 mm HEX	● approx. 3 bar	5270020	
11	7	7 mm HEX	● approx. 8-12 bar	5270022	

GW		M 8 x 1.0		Ref.- No.:	
L1	L2	SW	Opening pressure	Steel	SST303 SST316L
11.6	6	11 mm HEX	● approx. 2.5 bar	5244082	

GW		M 10 x 1.0		Ref.- No.:		
L1	L2	SW	Opening pressure	Steel	SST303	SST316L
11.6	4	11 mm HEX	● approx. 2.5 bar	5244084	5244083	5244088
11.6	6	11 mm HEX	● approx. 5 bar		* 5244080	
11.6	6	11 mm HEX	● approx. 5 bar	5244085		
11.6	6	11 mm HEX	● approx. 7.5 bar	5244089		

GW		R 1/8, 1/8 - 28 BSP		Ref.- No.:		
L1	L2	SW	Opening pressure	Steel	SST303	SST316L
11.6	6	11 mm HEX	● approx. 2.5 bar	5800017		
11.6	6	11 mm HEX	● approx. 5 bar	5244086	5244087	

*with BUNA ball

LOCKING PLUGS

The standard locking plugs for closure of bore-holes are made of steel, zinc-plated and passivated, and they are featured with a tapered thread.

The following types are representing a selection of the most commonly used locking plugs.

Upon request, UMETA manufactures locking plugs in further versions, with respect to the following:

- dimension
- material
- thread size
- thread form (e. g. with cylindrical thread)
- length
- etc.



Locking Plugs



- for subsequent closing of boreholes
- made of steel, zinc-plated and passivated, with tapered thread
- for other types and materials, please see table, or upon request

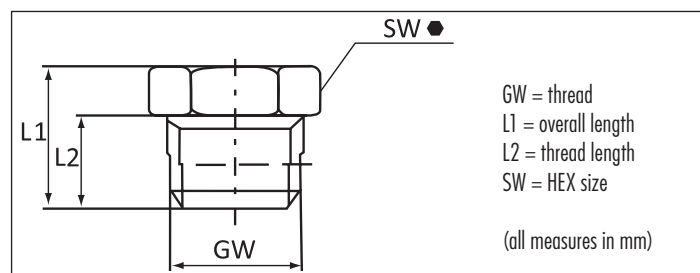

GW M 6 x 1.0			Ref.- No.:		
L1	L2	SW	Steel	SST303	SST316L
8.5	5.5	7 mm HEX	5180142		

GW M 12 x 1.5			Ref.- No.:		
L1	L2	SW	Steel	SST303	SST316L
12	8	14 mm HEX	5581136		

GW M 8 x 1.0			Ref.- No.:		
L1	L2	SW	Steel	SST303	SST316L
8.5	5.5	9 mm HEX	5180117		

GW R 1/8, 1/8 - 28 BSP			Ref.- No.:		
L1	L2	SW	Steel	SST303	SST316L
8.5	5.5	11 mm HEX	5180122		

GW M 10 x 1.0			Ref.- No.:		
L1	L2	SW	Steel	SST303	SST316L
9	5.5	11 mm HEX	5581133		
8	4.5	11 mm HEX	5180125		

GW 1/4"-28 UNF-2A			Ref.- No.:		
L1	L2	SW	Steel	SST303	SST316L
8.5	5.5	7 mm HEX	5180143		

Locking Plugs with Self-Forming Thread



- for subsequent closing of boreholes
- standard version made of steel, case-hardened according to DIN (650 HV) and yellow passivated
- with self-forming thread

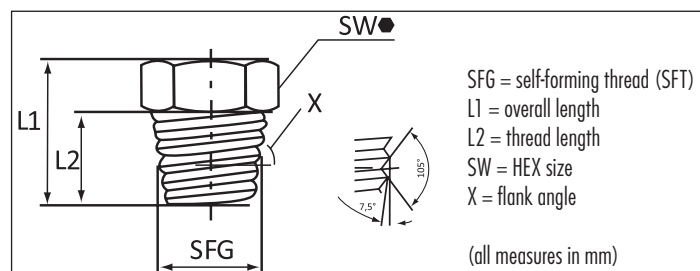

APPLICATION AREA

By using UMETA locking plugs with self-forming thread (SFT/SFG) you effectively save the thread-cutting process in the borehole.

MOUNTING INSTRUCTIONS

The special thread angle and the specific hardness level allow these plugs to be driven and screwed into boreholes without prior thread cutting.

Thus, the thread of the plug forms its counterhead. Later, the plug can easily be screwed out and be replaced by a standard locking plug. The exact size of the core hole depends on the material and must be determined by mounting tests. The consistency of the receiving material is decisive. The standard gauge for the installation bore diameter of 0.4-0.5 mm (= 0.02") below nominal width have proved in daily use.

SFG S 6 x 1			Ref.- No.:		
L1	L2	SW	Steel	not available in other materials	
8.5	5.5	7 mm HEX	5180146		

SFG S 8 x 1			Ref.- No.:		
L1	L2	SW	Steel	not available in other materials	
8.5	5.5	9 mm HEX	5180116		

UMETA History



Hermann
Ulrichskötter



Margarete Maser-
Ulrichskötter



Frank Maser



Administration



Site

- 1926** Company founded by Hermann Ulrichskötter
- 1953** Relocation of the company to current location in Ummeln, Bielefeld
- 1965** General management takeover by Margarete Maser-Ulrichskötter, daughter of Hermann Ulrichskötter
- 1993** Mr. Frank Maser enters the third generation of company general management
- 1993** Founding of a subsidiary in the USA
- 1994** Certification to DIN EN ISO 9001 as first company in the sector
- 2004** UMETA is awarded the „Bielefelder-Ökoprot-Betrieb 2004“ prize
- 2006** Extensive upgrade of machinery in the CNC machine sector to extend special turned part range
- 2007** TÜV certification to „customer satisfaction and service quality“
- 2011** Re-certification of our quality management to ISO 9001:2008
- 2011** Extensive upgrade of machinery in the CNC machine sector to extend special turned part range

Caution! Safety Information

It is imperative that you observe the following information:

UMETA grease guns can achieve a lubrication pressure of over 800 bar / 11,600 PSI.

For this reason, please ensure that all components are designed for this high pressure.

Service your UMETA products regularly!

Before using them first, check all connections for tight fit and only use components which do not show any signs of damage.

Never point the discharge opening at yourself or at other people.

Never hold onto hoses under pressure and never loosen connections which are under pressure.

Hoses are subject to a severe ageing process!

For this reason you should always replace hoses after three years at the latest. Hoses may never be buckled or bent with force. The smallest bending radius is 100 mm.

UMETA compressed air guns may never be operated under more than 10 bar / 145 PSI air pressure.

Special lubricating nipples may be required for lubrication using automatic lubricating equipment. Always inform yourself in advance about the maximum permissible pressure!

Only use UMETA products with original UMETA accessories which are intended for this purpose. Modifications to UMETA Products can lead to severe damage or injuries. If you are injured, consult a doctor immediately!

UMETA products may never be brought into contact with hazardous or aggressive materials.

General Information

We reserve the right to make changes to products with regard to technical properties, dimensions and materials, and to remove products from our range.

Products may deviate from catalogue illustrations in their design, colour and size.

Supply of turned parts takes place in accordance with our „Technical terms of delivery for turned parts“, which you can find in the download area of our Internet site.

Furthermore our General Conditions of Sale, which are on the back of our business paper and on our Internet site, apply to all deliveries.

Our 4 years guarantee is subject to our guarantee terms and conditions which can be found at www.umeta.com

We accept no liability for any errors or omissions.

www.umeta.com



UMETA REFERENCE INDEX

On which page do I find the requested UMETA reference number?

Ref. No.:	Page	UMETA-Type	Ref. No.:	Page	UMETA-Type	Ref. No.:	Page	UMETA-Type	Ref. No.:	Page	UMETA-Type
1100185	46	H1a	1120288	46	H1a	1304503	42	H3	3101462	54	D1
1100186	46	H1a	1120701	38	H1	1304504	42	H3	3101763	54	D1
1100187	46	H1a	1120703	38	H1	1304507	42	H3	3110186	57	D1a
1100288	46	H1a	1120704	38	H1	1304508	42	H3	3110288	57	D1a
1100289	46	H1a	1120737	39	H1	1304574	45	H3/S	3110389	57	D1a
1100290	46	H1a	1120744	39	H1	1304575	45	H3/S	3110724	54	D1
1100389	46	H1a	1120907	38	H1	1304578	45	H3/S	3110925	54	D1
1100701	38	H1	1120908	38	H1	1304586	47	H3a	3110926	54	D1
1100703	38	H1	1120938	39	H1	1304588	47	H3a	3111127	54	D1
1100704	38	H1	1121104	38	H1	1304709	42	H3	3111161	54	D1
1100737	39	H1	1121109	38	H1	1304756	43	H3	3111462	54	D1
1100744	39	H1	1121111	38	H1	1304767	43	H3	3120186	57	D1a
1100750	39	H1	1121139	39	H1	1304776	45	H3/S	3120288	57	D1a
1100774	44	H1/S	1121156	39	H1	1304789	47	H3a	3120724	54	D1
1100905	38	H1	1121414	38	H1	1310904	42	H3	3120925	54	D1
1100906	38	H1	1121415	38	H1	1310907	42	H3	3120926	54	D1
1100907	38	H1	1121457	39	H1	1310908	42	H3	3121127	54	D1
1100908	38	H1	1121758	39	H1	1310937	43	H3	3121161	54	D1
1100938	39	H1	1140186	46	H1a	1310944	43	H3	3121462	54	D1
1100945	39	H1	1140704	38	H1	1311109	42	H3	3204504	55	D2
1100951	39	H1	1140907	38	H1	1311156	43	H3	3204507	55	D2
1100975	44	H1/S	1140908	38	H1	1311457	43	H3	3204508	55	D2
1101104	38	H1	1141109	38	H1	1320904	42	H3	3204586	58	D2a
1101109	38	H1	1141111	38	H1	1320907	42	H3	3204588	58	D2a
1101110	38	H1	1141156	39	H1	1320908	42	H3	3204709	55	D2
1101111	38	H1	1141167	39	H1	1320937	43	H3	3204756	55	D2
1101139	39	H1	1141457	39	H1	1320944	43	H3	3204789	58	D2a
1101146	39	H1	1141468	39	H1	1320945	43	H3	3214504	55	D2
1101152	39	H1	1200901	40	H2	1321109	42	H3	3304504	55	D3
1101156	39	H1	1200903	40	H2	1321111	42	H3	3304507	55	D3
1101167	39	H1	1200904	40	H2	1321156	43	H3	3304508	55	D3
1101176	44	H1/S	1200905	40	H2	1321457	43	H3	3304586	58	D3a
1101412	38	H1	1200906	40	H2	1340907	42	H3	3304588	58	D3a
1101413	38	H1	1200907	40	H2	1341109	42	H3	3304709	55	D3
1101414	38	H1	1200908	40	H2	1341156	43	H3	3304756	55	D3
1101415	38	H1	1200937	41	H2	1341415	42	H3	3304789	58	D3a
1101417	38	H1	1200938	41	H2	1341457	43	H3	4101704	62	M1
1101418	39	H1	1200944	41	H2	1341630	42	H3	4101707	62	M1
1101440	39	H1	1200945	41	H2	1400904	40	H2	4101708	62	M1
1101457	39	H1	1200950	41	H2	1400907	40	H2	4101709	62	M1
1101468	39	H1	1200951	41	H2	1400908	40	H2	4101711	62	M1
1101719	39	H1	1200977	45	H2/S	1400937	41	H2	4101714	62	M1
1101758	39	H1	1201109	40	H2	1400938	41	H2	4101715	62	M1
1101769	39	H1	1201110	40	H2	1400944	41	H2	4101717	62	M1
1110186	46	H1a	1201111	40	H2	1400945	41	H2	4101719	62	M1
1110288	46	H1a	1201139	41	H2	1401109	40	H2	4101732	62	M1
1110701	38	H1	1201146	41	H2	1401139	41	H2	4101761	62	M1
1110703	38	H1	1201152	41	H2	1401140	41	H2	4101762	62	M1
1110704	38	H1	1201156	41	H2	1401156	41	H2	4101763	62	M1
1110737	39	H1	1201412	40	H2	1404504	40	H2	4101768	62	M1
1110744	39	H1	1201414	40	H2	1404507	40	H2	4111704	62	M1
1110907	38	H1	1201415	40	H2	2100186	52	K1a	4111707	62	M1
1110908	38	H1	1201417	40	H2	2100288	52	K1a	4111708	62	M1
1110938	39	H1	1201440	41	H2	2100389	52	K1a	4111709	62	M1
1111109	38	H1	1201457	41	H2	2100701	50	K1	4111711	62	M1
1111111	38	H1	1201468	41	H2	2100703	50	K1	4111714	62	M1
1111139	39	H1	1201719	40	H2	2100704	50	K1	4111715	62	M1
1111156	39	H1	1201758	41	H2	2100905	50	K1	4111761	62	M1
1111167	39	H1	1201769	41	H2	2100907	50	K1	4111762	62	M1
1111414	38	H1	1204503	40	H2	2100908	50	K1	4111763	62	M1
1111457	39	H1	1204504	40	H2	2101109	50	K1	4121704	62	M1
1120186	46	H1a	1204507	40	H2	2101111	50	K1	4121707	62	M1
			1204508	40	H2	2101156	50	K1	4121708	62	M1

Ref.- No.:	Page	UMETA-Type
4121709	62	M1
4121711	62	M1
4121714	62	M1
4121715	62	M1
4121761	62	M1
4121762	62	M1
4121763	62	M1
4141704	62	M1
4141707	62	M1
4141709	62	M1
4141761	62	M1
4141762	62	M1
4141763	62	M1
4141768	62	M1
4201104	61	M4
4201107	61	M4
4201109	61	M4
4201161	61	M4
4221161	61	M4
4302210	63	M22
4302219	63	M22
4302262	63	M22
4302263	63	M22
4302264	63	M22
4312219	63	M22
4312262	63	M22
4312263	63	M22
4322219	63	M22
4322262	63	M22
4322263	63	M22
4402262	63	M22/L
4402263	63	M22/L
4402264	63	M22/L
4501504	64	T1
4501507	64	T1
4501508	64	T1
4501509	64	T1
4501511	64	T1
4501537	64	T1
4501561	64	T1
4501562	64	T1
4601504	65	T1B
4601507	65	T1B
4601508	65	T1B
4601509	65	T1B
4601511	65	T1B
4601514	65	T1B
4601516	65	T1B
4601537	65	T1B
4601539	65	T1B
4601561	65	T1B
4601562	65	T1B
4611504	65	T1B
4611507	65	T1B
4611508	65	T1B
4611509	65	T1B
4611511	65	T1B
4611514	65	T1B
4611560	64	T1
4611561	65	T1B
4611562	65	T1B
4621509	65	T1B
4621514	65	T1B
4621561	65	T1B
4621562	65	T1B
4641561	65	T1B

4641562	65	T1B
4641567	65	T1B
5180117	81	Plug
5180122	81	Plug
5180125	81	Plug
5180142	81	Plug
5180143	81	Plug
5240009	66	M/Special
5240013	66	M/Special
5240020	66	M/Special
5240046	66	M/Special
5240048	66	M/Special
5240061	66	M/Special
5240062	66	M/Special
5240063	66	M/Special
5240067	67	M/Special
5241007	38	H1
5241009	38	H1
5241014	44	H1/S
5241024	39	H1
5241029	46	H1a
5241038	38	H1
5241040	46	H1a
5241043	74	H1a/SAE
5241054	39	H1
5241055	39	H1
5241056	38	H1
5241057	38	H1
5241058	39	H1
5241059	38	H1
5241060	38	H1
5241061	39	H1
5241062	39	H1
5241068	39	H1
5241070	39	H1
5241071	39	H1
5241072	39	H1
5241074	38	H1
5241075	39	H1
5241076	39	H1
5241077	39	H1
5241080	39	H1
5241097	46	H1a
5241101	38	H1
5241102	38	H1
5241103	39	H1
5241105	39	H1
5241106	39	H1
5241130	49	H/Special
5241131	49	H/Special
5241132	49	H/Special
5241133	49	H/Special
5241135	44	H1/S
5241140	49	H/Special
5241213	49	H/Special
5241236	41	H2
5242042	48	H/Special
5242085	40	H2
5242087	41	H2
5242088	40	H2
5242092	42	H3
5242093	43	H3
5242104	41	H2
5242105	41	H2
5243010	59	DV1
5243018	59	DV1
5243019	59	DV1

Ref.- No.:	Page	UMETA-Type
5243020	59	DV1
5243021	59	DV1
5243067	59	DV1
5243068	59	DV1
5243069	59	DV1
5244033	49	H/Special
5244080	80	Valves
5244082	80	Valves
5244083	80	Valves
5244084	80	Valves
5244085	80	Valves
5244086	80	Valves
5244087	80	Valves
5244088	80	Valves
5244089	80	Valves
5244094	49	H/Special
5244095	49	H/Special
5244096	49	H/Special
5244134	49	H/Special
5244159	49	H/Special
5244160	49	H/Special
5244161	49	H/Special
5244162	49	H/Special
5244163	49	H/Special
5244178	49	H/Special
5244179	49	H/Special
5244181	49	H/Special
5244185	59	D3 quattro
5270020	80	Valves
5270022	80	Valves
5313742	38	H1
5313742	71	H1/SAE
5317443	44	H1/S
5317541	44	H1/S
5372717	65	T1B
5376214	66	M/Special
5376314	66	M/Special
5544053	67	M/Special
5544054	67	M/Special
5544056	67	M/Special
5544057	67	M/Special
5546006	71	H1/SAE
5546008	71	H1/SAE
5546010	71	H1/SAE
5546012	71	H1/SAE
5546016	71	H1/SAE
5546017	72	H2/SAE
5546018	72	H2/SAE
5546020	72	H2/SAE
5546022	72	H2/SAE
5546024	72	H3/SAE
5546026	72	H3/SAE
5546028	71	H1/SAE
5546030	71	H1/SAE
5546032	71	H1/SAE
5546034	71	H1/SAE
5546036	71	H1/SAE
5546038	71	H1/SAE
5546040	72	H2/SAE
5546042	72	H2/SAE
5546044	72	H3/SAE
5546046	73	H1/S/SAE
5546048	73	H2/S/SAE
5546050	74	H3/S/SAE
5546052	73	H1/S/SAE

5546054	73	H2/S/SAE
5546056	74	H3/S/SAE
5546060	74	H1a/SAE
5546062	74	H1a/SAE
5546064	74	H1a/SAE
5546066	74	H1a/SAE
5546068	74	H1a/SAE
5546070	74	H1a/SAE
5546072	74	H1a/SAE
5546074	74	H1a/SAE
5546076	74	H1a/SAE
5546078	74	H1a/SAE
5546080	75	H2a/SAE
5546082	75	H2a/SAE
5546085	72	H2/SAE
5546086	71	H1/SAE
5546087	71	H1/SAE
5546088	72	H3/SAE
5546089	72	H3/SAE
5546090	72	H2/SAE
5546106	71	H1/SAE
5546108	72	H2/SAE
5546110	71	H1/SAE
5546112	76	M1/SAE
5546114	76	M1/SAE
5546116	76	M1/SAE
5546120	77	M22/SAE
5546122	75	H/SAE
5546124	76	DV1/SAE
5546126	76	DV1/SAE
5546128	76	DV1/SAE
5546130	75	D1/SAE
5546132	77	Adapter/SAE
5546134	77	Adapter/SAE
5546135	77	Adapter/SAE
5546138	78	Plug/SAE
5546140	78	Plug/SAE
5546152	72	H2/SAE
5546153	72	H2/SAE
5546154	71	H1/SAE
5546157	77	Adapter/SAE
5546159	77	Adapter/SAE
5546503	71	H1/SAE
5546507	71	H1/SAE
5547001	71	H1/SAE
5547020	76	M1/Iso
5547021	76	M1/Iso
5547022	76	M1/Iso
5556010	28	Filling cyl.
5581133	81	Plug
5581136	81	Plug
5800017	80	Valves
5800040	48	H/Special
5800048	48	H/Special
5800049	48	H/Special
5800050	48	H/Special
5800051	48	H/Special
5800052	48	H/Special
5800053	48	H/Special
5800054	48	H/Special
5800056	48	H/Special
5800057	48	H/Special
5800058	70	Garage equ.
5800059	70	Garage equ.
6008100	69	Assortment
6008102	69	Assortment
6017140	69	Assortment

Ref.- No.:	Page	UMETA-Type
6017141	69	Assortment
6035140	69	Assortment
6110100	77	Assort./SAE
6800130	10	75/PKU
6800140	10	75/PKU
6900095	10;	Case kit
	30	
6900096	10;	75/PKU
	30	
6900098	10;	75/PKU
	30	
6900099	25	Wall bracket
7000000	12	EcoLube
7000002	12	EcoLube
7000003	12	EcoLube
7000005	12	EcoLube
7021312	10	75/PKU
7021411	10	75/PKU
7091156	34	75/PKI zinc
7091157	34	75/PKI zinc
7091312	35	75/LL zinc
7092100	25	Wall bracket
7092110	25	Wall bracket
7130133	15	30/S
7130233	15	30/H
7130433	15	30
7130533	15	30/NS
7133933	15	30/K
7134133	15	34/S
7134233	15	34/H
7134433	15	34
7134533	15	34/NS
7135933	15	34/K
7136113	16	36/S
7136213	16	36/H
7136313	16	36/NS
7136413	16	36
7136513	16	36/K
7140133	16	40/S
7140233	16	40/H
7140333	16	40/NS
7140433	16	40
7140533	16	40/K
7142133	16	42/S
7142233	16	42/H
7142433	16	42
7142533	16	42/NS
7142733	16	42/K
7143133	18	43/S
7143233	18	43/H
7144133	16	44/S
7144233	16	44/H
7144433	16	44
7144533	16	44/NS
7144753	16	44/K
7146113	17	46/S
7146213	17	46/H
7146313	17	46/NS
7146413	17	46
7146753	17	46/K
7212443	28	Type 2/V
7222143	27	Type 2
7233113	27	Type 3
7244313	28	Type 4
7255113	29	SDG 10
7256313	29	SDG 13

7265113	29	SDK 10
7266313	29	SDK 13
7277113	29	SDF 10
7277313	29	SDF 13
7321151	24	Coupler
7321551	24	Coupler
7321651	24	Coupler
7321751	24	Coupler
7321851	24	Coupler
7322451	24	Coupler
7323911	24	Coupler
7331911	22	Joint
7331921	22	Joint
7331925	22	Joint
7331941	22	Joint
7351031	21	Nozzle
7351041	21	Nozzle
7351061	21	Nozzle
7351161	21	Nozzle
7351261	21	Nozzle
7351314	21	Nozzle
7351315	21	Nozzle
7351316	21	Nozzle
	22	(oil)
7351317	21	Nozzle
7351326	21	Nozzle
	22	(oil)
7351376	21	Nozzle
	22	(oil)
7351461	21	Nozzle
7351561	21	Nozzle
7353361	21	Nozzle
7368011	22	Coupler
7368012	22	Coupler
7368015	22	Coupler
7371953	25;	Grease
	33	
7437505	14	DRP 30
7522224	32	Accessories
7523224	32	Accessories
7525224	32	Accessories
7591483	31	Filling dev.
7591583	31	Filling dev.
7591683	31	Filling dev.
7591783	31	Filling dev.
7591883	31	Filling dev.
7591983	31	Filling dev.
7611113	17	Model 21
7611213	17	Model 21
7751511	10	75/PKU
7751611	10	75/PKU

Ref.- No.:	Page	UMETA-Type
9230004	24	Coupler
9500110	70	Cap
9500111	70	Cap
9500120	70	Cap
9500121	70	Cap
9500130	70	Cap
9500131	70	Cap
9500140	70	Cap
9500141	70	Cap
9500200	70	Cap
9500201	70	Cap
9500210	70	Cap
9626103	33	Accessories
9626109	33	Accessories
9626140	33	Accessories
9626396	33	Accessories
9626700	32	Accessories
9626701	32	Accessories
9626702	32	Accessories
9626705	32	Accessories
9626708	32	Accessories
9626707	32	Accessories
9626725	32	Accessories
9626800	32	Accessories
9626801	32	Accessories
9626802	32	Accessories
9626803	32	Accessories
9626805	32	Accessories
9626810	33	Accessories
9626820	31	Oil pump
9626825	30	Carry Lube
9626830	31	Oil pump
9907126	24	Coupler
9907127	24	Coupler
9907128	24	Coupler
V000039	23	360/LN
V000041	23	360/LN
V000042	23	360/L
V000044	20	Nozzle tube
V000054	20	Nozzle tube
V000055	20	Nozzle tube
V000072	20	Nozzle tube
V000074	20	Nozzle tube
V000076	20	Nozzle tube
V000077	21	Nozzle
V000084	22	Coupler
V000085	22	Coupler
V000088	22	Coupler
V000095	22	Coupler
V000096	22	Coupler
V000097	22	Coupler
V000098	22	Coupler
V000100	21	Nozzle
V000101	20	Nozzle tube
V000102	21	Nozzle
V000103	20	Nozzle tube
V000104	21	Nozzle
V000106	21	Nozzle
V000108	23	360/LN
V000109	23	360/LN
V000145	23	360/LN
V000154	20	Nozzle tube
V000155	20	Nozzle tube
V000200	23	360/L
V000210	13	85/PK silver
V000211	11	73/PK

V000223	23	360/LN
V000224	22	Coupler
V000227	21	Nozzle
V000239	22	Oil coupler
V000246	21	Nozzle
V000247	20	Nozzle tube
V000248	21	Nozzle
V000250	21	Nozzle
V000252	21	Nozzle
V000253	20	Nozzle tube
V000254	21	Nozzle
V000276	8	75/PK silver
V000279	20	Nozzle tube
V000281	8	75/PK silver
V000282	23	360/L
V000283	23	360/LN
V000285	20	Nozzle tube
V000286	8	75/PK silver
V000287	8	75/PK silver
V000288	23	360/LN
V000294	23	360/L
V000297	23	360/L
V000298	23	360/LN
V000301	8	75/PK zinc
V000306	8	75/PK silver
V000308	8	75/PK silver
V000309	8	75/PK zinc
V000310	8	75/PK zinc
V000311	23	360/L
V000312	23	360/LN
V000316	20	Nozzle tube
V000318	23	360/LN
V000319	8	75/PK silver
V000321	22	coupler
V000323	23	360/LN
V000325	22	coupler
V000326	23	360/LN
V000327	23	360/LN
V000328	23	360/LN
V000330	22	Oil coupler
V000331	22	coupler
V000332	23	360/L
V000333	8	75/PK silver
V000334	35	75/PKI zinc
V000337	20	Nozzle tube
V000340	35	75/LLI zinc
V000342	8	75/PK silver
V000349	8	75/PK zinc
V000350	11	70/PK
V000354	11	70/PK
V000358	8	75/PK zinc
V000361	22	Oil coupler
V000366	23	360/LN
V000369	13	85/PK zinc
V000371	13	85/PK silver
V000375	20	Nozzle tube
V000378	8	75/PK silver
V000382	13	85/PK silver
V000391	12	75/PKM
V000392	12	75/PKM
V000394	23	360/LN
V000398	20	Nozzle tube
V000402	8	75/PK silver
V000403	8	75/PK silver
V000410	23	360/L
V000420	13	85/PK silver
V000421	13	85/PK silver

Ref.- No.:	Page	UMETA-Type
V000431	13	85/PK zinc
V000432	8	75/PK zinc
V000439	9	75/PL zinc
V000443	11	70/PK
V000449	8	75/PK silver
V000454	13	85/PK silver
V000456	8	75/PK silver
V000457	11	73/PK
V000458	11	73/PK
V000465	23	360/L
V000471	23	360/L
V000472	11	70/PK
V000475	23	360/L
V000476	23	360/LN
V000479	11	73/PK
V000485	12	75/PKM
V000486	9	75/PL zinc
V000490	23	360/L
V000495	8	75/PK silver
V000496	23	360/L
V000499	12	75/PKM
V000507	13	85/PK silver
V000521	23	360/L
V000524	8	75/PK silver
V000525	9	75/PL zinc
V000535	8	75/PK silver
V000538	13	85/PK silver
V000545	12	75/PKM
V000548	13	85/PK zinc
V000549	11	73/PK
V000550	11	70/PK
V000567	8	75/PK zinc
V000573	8	75/PK zinc
V000616	8	75/PK silver
V000617	13	85/PK silver
V000637	11	70/PK
V000640	13	85/PK silver
V000645	11	70/PK
V000647	9	75/LL zinc
V000648	9	75/LL zinc
V000650	23	360/LN
V000651	23	360/LN
V000652	23	360/LN
V000653	23	360/L
V000662	9	75/PL zinc
V000666	22	coupler
V000667	8	75/PK silver
V000676	13	85/PK zinc
V000682	23	360/LN
V000683	23	360/LN
V000684	23	360/LN
V000685	23	360/LN
V000686	23	360/L
V000687	23	360/L
V000688	23	360/L
V000689	23	360/L
V000691	23	360/L
V000704	13	85/PK silver
V000712	12	75/PKM
V000715	13	85/PK zinc
V000717	8	75/PK silver
V000721	13	85/PK zinc
V000730	13	85/PK zinc
V000741	23	360/L
V000761	23	360/L
V000768	13	85/PK silver

V000771	13	85/PK silver
V000772	13	85/PK silver
V000773	11	73/PK
V000790	11	70/PK
V000803	9	75/PL zinc
V000809	13	85/PK zinc
V000810	9	75/PL zinc
V000842	11	70/PK
V000858	13	85/PK zinc
V000859	12	75/PKM
V000860	8	75/PK zinc
V000881	11	70/PK
V000938	9	75/LL zinc
V000940	23	360/LN
V000941	9	75/LL zinc
V000952	11	70/PK
V000961	13	85/PK zinc
V000978	12	75/PKM
V000993	11	73/PK
V000997	13	85/PK silver
V001002	11	70/PK
V001020	23	360/L
V001024	11	73/PK
V001028	13	85/PK zinc
V001045	8	75/PK silver
V001048	23	360/LN
V001049	23	360/LN
V001054	11	73/PK
V001093	9	75/PL zinc
V001094	11	70/PK
V001095	11	70/PK
V001096	11	73/PK
V001097	11	73/PK
V001118	11	70/PK
V001129	9	75/PL zinc
V001136	13	85/PK silver
V001157	13	85/PK zinc
V001167	8	75/PK zinc
V001172	8	75/PK zinc
V001174	8	75/PK silver
V001176	8	75/PK silver
V001181	8	75/PK zinc
V001182	8	75/PK zinc
V001184	8	75/PK zinc
V001185	8	75/PK zinc
V001187	13	85/PK zinc
V001188	13	85/PK zinc
V001189	13	85/PK zinc
V001190	13	85/PK zinc
V001192	13	85/PK zinc
V001194	13	85/PK zinc
V001195	13	85/PK zinc
V001196	13	85/PK zinc
V001197	9	75/PL zinc
V001198	9	75/PL zinc
V001199	9	75/PL zinc
V001200	9	75/PL zinc
V001206	23	360/L
V001207	23	360/L
V001208	23	360/L
V001209	23	360/L
V001210	23	360/L
V001211	11	70/PK
V001212	9	75/LL zinc
V001213	9	75/LL zinc
V001214	9	75/LL zinc

Ref.- No.:	Page	UMETA-Type
V001218	11	73/PK
V001219	11	73/PK
V001220	11	73/PK
V001224	11	73/PK
V001227	11	73/PK
V001229	9	75/LL zinc
V001232	9	75/LL zinc
V001233	9	75/LL zinc
V001249	8	75/PK zinc
V001250	8	75/PK zinc
V001251	11	70/PK
V001408	8	75/PK zinc
V001409	8	75/PK zinc
V001422	9	75/PL zinc
V001425	22	Coupler
V001426	22	Coupler
V001440	35	75/PKI zinc
V001460	9	75/PL zinc
V001461	9	75/PL zinc
V001462	9	75/PL zinc
V001463	9	75/PL zinc
V001464	9	75/PL zinc
V001465	9	75/PL zinc
V001466	11	70/PK
V001467	11	70/PK
V001468	11	70/PK
V001469	13	85/PK silver
V001470	13	85/PK silver
V001471	13	85/PK silver
V001472	13	85/PK silver
V001473	13	85/PK silver
V001474	13	85/PK silver
V001478	35	75/LLI zinc
V001479	11	73/PK
V001480	11	73/PK
V001481	11	73/PK
V001482	11	73/PK
V001502	18	70/PKO
V001549	18	70/PKO
V001550	18	70/PKO
V001551	18	70/PKO
V001552	18	70/PKO
V001553	18	70/PKO
V001554	18	70/PKO
V001555	18	70/PKO
V001557	18	70/PKO
V001558	18	70/PKO
V001559	18	70/PKO
V001560	18	70/PKO
V001625	22	Coupler
V001662	23	360/LN
V001663	23	360/LN
V001672	23	360/L
V001673	23	360/L

UMETA Hermann Ulrichskötter
Metallwarenfabrik GmbH & Co. KG



Almestraße 1-3 · 33649 Bielefeld · Germany
Fon: +49 (0)521.948-0 · Fax: +49 (0)521.948-111
E-Mail: info@umeta.com · www.umeta.com

UMETA OF AMERICA INC.



147 Bluewing Lane
 Mooresville, NC 28117 · USA
Fon: 001-704-799-1840 · Fax: 704-799-1923
E-mail: usa@umeta.com · www.umetausa.com

We make it move.